

# Main Stub-Out Assemblies

*By GHP Systems, Inc.*

---

## PRODUCT COMPONENT SUBMITTALS

- Pipe
- Fittings
- Valves



GHP Systems, Inc.  
1000 32<sup>nd</sup> Avenue  
Brookings, SD 57006  
[www.ghpsystems.com](http://www.ghpsystems.com)

(605) 697-7867 tel  
(605) 697- 9118 fax  
888-447-7757 toll-free

## PRODUCT SUBMITTAL

Project Name: \_\_\_\_\_

Project Location: \_\_\_\_\_

Contractor: \_\_\_\_\_

### DRISCOPLEX<sup>®</sup> 5300 CLIMATE GUARD<sup>®</sup> PIPE AND FITTINGS

#### Scope:

This Product Submittal is for DriscoPlex<sup>®</sup> 5300 Climate Guard<sup>®</sup> pipe and fittings for geothermal (ground source heat pump) applications.

#### Reference Documents:

DriscoPlex<sup>®</sup> 5300 Climate Guard<sup>®</sup> pipe is manufactured in accordance with ASTM D-3035. Where applicable, DriscoPlex<sup>®</sup> 5300 Climate Guard fittings are manufactured in accordance with ASTM D-2683 for socket fusion fittings, ASTM D-3261 for butt fusion fittings,

#### Materials:

DriscoPlex<sup>®</sup> 5300 Climate Guard<sup>®</sup> polyethylene pipe and heat fused materials are manufactured from high density polyethylene material meeting ASTM D-3350 cell classification 345464C. The material has a 1600 psi Hydrostatic Design Basis at 73°F per ASTM D-2837 and is listed in the manufacturers name in PPI TR4 as a PE3608 compound.

#### Certification:

Performance Pipe certifies that DriscoPlex<sup>®</sup> 5300 Climate Guard<sup>®</sup> pipe and fittings meet the specifications and requirements identified herein.

#### Limited Warranty Summary:

Performance Pipe warrants, subject to specific conditions, Climate Guard<sup>®</sup> 5300 Series pipe and fusion fittings for a period of 50 years against rust, rot, electrolytic corrosion and defects in workmanship and materials. This warranty is valid when pipe, tubing and/or fittings are utilized and installed in a closed loop geothermal heat pump system in accordance with accepted and approved industry guidelines and practices. (See Full Limited Warranty for complete terms, conditions and disclaimers).

**PERFORMANCE PIPE**, a division of Chevron Phillips Chemical Company LP

PO Box 269006 / Plano, TX 75026-9006

Phone: 1-800-527-0662 / Fax: 972-599-7348

[www.performancepipe.com](http://www.performancepipe.com)



---

## **DRISCOPLEX<sup>®</sup> 5300 Series Climate Guard<sup>®</sup> Polyethylene Pipe and Fusion Fittings Limited Warranty**

---

### **5300 Series Products:**

Performance Pipe warrants DriscoPlex<sup>®</sup> 5300 Series Climate Guard<sup>®</sup> pipe and fusion fittings for a period of 50 years against defects in workmanship and materials. This warranty is valid when pipe and/or fittings are utilized and installed in a closed loop geothermal heat pump system in accordance with accepted and approved industry guidelines and practices. This warranty applies only to Performance Pipe DriscoPlex<sup>®</sup> 5300 Series Climate Guard<sup>®</sup> pipe and fusion fittings. It does not apply to any fusion joining process or any other method or device used to join the pipe or fusion fitting performed by any other party. It does not apply to the design or installation of the system or any other component of the system.

Subject to the price adjustments described below, Performance Pipe will replace, with a like quantity of new products, any DriscoPlex<sup>®</sup> 5300 Series Climate Guard<sup>®</sup> pipe or fusion fittings that were installed and utilized as described above and that subsequently fail within fifty (50) years from the date of purchase due to a defect in workmanship or materials. For warranty claims occurring within one year after the date of purchase, the defective product(s) shall be replaced free of product and freight charges. For warranty claims occurring during the second (2<sup>nd</sup>) through eleventh (11<sup>th</sup>) years after the date of purchase, the replacement product cost and freight expense borne by Performance Pipe shall be calculated by reducing the then current price by eight percent (8%) per year. For warranty claims occurring during the twelfth (12<sup>th</sup>) through the fiftieth (50<sup>th</sup>) years after the date of purchase, the replacement product cost and freight expense borne by Performance Pipe shall be calculated by reducing the then current price by eighty percent (80%) plus one half percent (0.5%) per year for each year after the 11<sup>th</sup> year.

**SUBJECT TO ANY EXPRESS WARRANTIES CONTAINED IN PERFORMANCE PIPE'S SALES ORDER APPLICABLE TO THE PRODUCT(S) IN QUESTION, THIS LIMITED WARRANTY IS IN LIEU OF ALL OTHER WARRANTIES, WHETHER WRITTEN, ORAL, EXPRESS OR IMPLIED, AND PERFORMANCE PIPE DISCLAIMS ANY EXPRESS OR IMPLIED WARRANTIES OF MERCHANTABILITY AND FITNESS FOR A PARTICULAR PURPOSE. PERFORMANCE PIPE SHALL NOT BE LIABLE FOR SPECIAL, INDIRECT, INCIDENTAL OR CONSEQUENTIAL DAMAGES RELATING TO DEFECTS OF PERFORMANCE PIPE DRISCOPLEX<sup>®</sup> 5300 SERIES CLIMATE GUARD<sup>®</sup> PIPE AND FUSION FITTINGS, WHETHER USED SINGULARLY OR IN COMBINATION WITH OTHER PRODUCTS OR MATERIALS.** Some states do not allow this exclusion, so it may not apply to you. This limited warranty gives the purchaser specific legal rights and there may be other rights, which vary from state to state.



---

## DRISCOPEX<sup>®</sup> 5300 SERIES CLIMATE GUARD<sup>®</sup> SYSTEMS



---

DRISCOPEX<sup>®</sup> Series 5300 Climate Guard<sup>®</sup>  
HDPE Pipe and Fitting System for  
Closed-Loop Ground-Source  
Heat Pump Applications

Bulletin: PP 650

## DRISCOPEX® 5300 Series Climate Guard®

HDPE Pipe and Fitting System for  
Closed-Loop Ground-Source Heat Pump Applications

### Performance Pipe

PERFORMANCE PIPE is the functional successor to the operations of Plexco<sup>1</sup> and Driscopipe<sup>2</sup>. On July 1, 2000, Chevron Chemical Company and Phillips Chemical Company were joined to form Chevron Phillips Chemical Company LP. Performance Pipe, a division of Chevron Phillips Chemical Company LP, succeeds Plexco and Driscopipe as North America's largest producer of polyethylene piping products for geothermal, industrial, municipal, mining, oilfield, gas and utility applications.

Performance Pipe offers more than forty years of polyethylene pipe manufacturing experience with nine ISO certified manufacturing facilities.

The unmatched quality and performance of Performance Pipe polyethylene piping products is enhanced and strengthened with over four decades of quality polyolefin plastic resin production from Chevron Phillips Chemical Company LP.

### ***DRISCOPEX® 5300 Series Climate Guard® Pipe and Fitting System***

DriscoPlex® 5300 Series Climate Guard® high-density polyethylene pipe and fittings are the quality piping system for closed-loop, earth-coupled heat pump applications. DriscoPlex® 5300 Series Climate Guard® pipe and fittings are the system of choice for residential, commercial, institutional and industrial installations. Performance Pipe offers a complete system of DriscoPlex® 5300 pressure-rated pipe and fittings that meet applicable IGSHA and ASTM specifications and requirements.

### ***DRISCOPEX® 5300 Climate Guard® Systems - The Key to Performance***

**Economical** - Easy to join, lightweight and flexible to help reduce construction and installation costs.

**Tough and Durable** - Excellent impact and abrasion resistance. Pressure ratings based on long-term tests. Exceptional resistance to slow crack growth and environmental stress cracking.



<sup>1</sup> Formerly - Plexco, a Division of Chevron Chemical Company

<sup>2</sup> Formerly - Phillips Driscopipe, A Division of Phillips Petroleum Company

**NOTICE - This publication is intended for use as a guide to support the designer of piping systems. It is not intended to be used as installation instructions, and should not be used in place of the advice of a professional engineer. It does not constitute a guarantee or warranty for piping installations. Performance Pipe has made every reasonable effort to ensure the accuracy of this publication, but it may not provide all necessary information, particularly with respect to special or unusual applications. This publication may be changed from time to time without notice. Contact Performance Pipe to determine if you have the most current edition.**

**Ductile and Flexible** - Flexible DriscoPlex® 5300 Climate Guard® Series pipe follows the "lay of the land" to ease trench and down hole installation.

**Resistant to Chemicals and Corrosion** - Excellent resistance to most chemical compounds and aggressive soils.

**Thermally Conductive** - DriscoPlex® 5300 Climate Guard® pipe offers high strength PE 3408 to minimize pipe wall thickness and maximize heat transfer.

**Leak-Tight Joining** - Long, continuous coils or straight lengths reduce joining requirements. Properly made heat fusion joints are as strong as the pipe itself and do not leak.

**Excellent Hydraulics** - DriscoPlex® 5300 Climate Guard® pipe offers high volume flows with low flow resistance. The hydraulically smooth, non-wetting surface provides excellent flow properties. A Hazen-Williams C-factor of 150-155 is typically used to estimate flow resistance. DriscoPlex® 5300 Climate Guard® pipe does not rust, rot, corrode, tuberculate or support biological growth.

**Sequential Footage Markings** on coils to assist with proper depth setting in borehole installations.

## DRISCOPEX® 5300 Climate Guard® Pipe and Fitting Products

### *Pipe and Fittings*

- PE 3608 DR 11- 3/4" IPS, 1" IPS, 1-1/4" IPS, 1-1/2" IPS, 2" IPS, 3" IPS and 4" IPS standard.
  - PE 3608 DR 15.5 - 3" IPS, 4" IPS, 6" IPS and 8" IPS standard.
  - Other sizes through 54" IPS.
  - DriscoPlex® 5300 Climate Guard® Unicoil™ proprietary twin-coil with patented Polywing™ u-bend for down hole or horizontal loop applications - 3/4" IPS, 1" IPS and 1-1/4" IPS
- DriscoPlex® 5300 Climate Guard® molded fittings for butt fusion through 8" IPS and for socket fusion through 4" IPS.

### *Materials and Standards*

DriscoPlex® 5300 Climate Guard® pipe and molded fittings are manufactured from high-density, high molecular weight PE 3608 polyethylene compound that meets or exceeds ASTM D 3350 cell classification 345464C, and is listed by the Plastic Pipe Institute in PPI TR-4 with HDB ratings of 1600 psi (11.04 MPa) at 73°F (23°C) and 800 psi (5.52 MPa) at 140°F (60°C).

DriscoPlex® 5300 Climate Guard® pipe is manufactured in accordance with ASTM D 3035. Molded fittings are manufactured in accordance with ASTM D 3261 (butt outlet) and ASTM D 2683 (socket outlet).

## Secure Joining

DriscoPlex® 5300 Climate Guard® pipe and fittings are joined by socket, butt or saddle heat fusion, electrofusion, or mechanical fittings. Climate Guard® 5300 mechanical connection fittings are available for joining to other materials or to itself. Suitable electrofusion fittings may also be used. Heat fusion joining procedures are available upon request.

## Unicoil™ U-Bend Coil

### *Pre-Fused Polyethylene U-Bend Coils for Efficient, Reliable Installation*

Until now, installers have spent precious field time fabricating u-bends from elbows and making-up u-bend coils for down hole and horizontal heat pump piping loops. But no more - Now there is Unicoil™ u-bend coil from Performance Pipe.

Unicoil™ u-bend coil is the original pre-fused polyethylene u-bend coil system created by Performance Pipe. Unicoil™ u-bend coil features the patented one-piece Polywing Unibend that is pre-fused to two coils of DriscoPlex® 5300 Climate Guard® pipe, all in one convenient package.

### *Unibend with Polywing - It Goes Down Easy, and Stays Down*

Unibend is the first tight radius one-piece u-bend designed specifically for geothermal heat pump applications. The unique Unibend is factory pre-fused to two lengths of DriscoPlex® 5300 Climate Guard® pipe (supply and return) that are coiled together and banded into a single package for easy handling and quick field installation. Unibend features a pointed end for self-guiding installation to slide through the toughest borehole conditions. The one-piece Unibend design eliminates the third fusion where two elbows are fused together, thus fewer joints are buried at extreme depths.

Unibend features the patented Polywing anti-buoyancy attachment port to minimize the possibility of a loop assembly "floating" out of the borehole. When an anti-buoyancy wing tube is fitted through the Polywing attachment port, the wing tube folds against the Unibend during down-hole insertion, but the wing tube springs out to resist buoyant forces. The Polywing anti-buoyancy port may also be used to connect weights, stiffeners, or other devices without risking damage or compromising Unibend performance.



## Configurations

DriscoPlex® 5300 Climate Guard® Unicoil™ piping systems are available in three pipe sizes and two pressure ratings.

- Pipe sizes: 3/4" IPS, 1" IPS or 1-1/4" IPS
- Working pressure ratings: SDR 11 160 psi water at 73°F (standard) or SDR 9 200 psi water at 73°F (special order) for deep installations or high static pressures.
- Outside width across Unibend†: 

3/4" IPS & 1" IPS	3 1/4" wide
1-1/4" IPS	4" wide

† This dimension is the approximate outside width across the Unibend at the end of the Unicoil™ u-bend coil including the fusion beads. When used in downhole applications, appropriate clearance between the borehole and the outside width of the Unibend is required to allow downhole passage.

DriscoPlex® 5300 Climate Guard® Unicoil™ geothermal piping systems sets the standard for reliability, cost-efficiency and ease of installation in the ground source heat pump industry.

### **General Guidelines for Closed-Loop Ground-Source Heat Pump Applications**

- Verify that the total system pressure, operating plus surge, does not exceed the pressure rating of the lowest rated component in the system.
- Carefully inspect the pipe to detect any damage that may have occurred during shipping or handling.
- Conduct hydrostatic leak testing in accordance with Performance Pipe or accepted industry practices and procedures. *Do not test piping with pressurized air.*
- Install DriscoPlex® 5300 Climate Guard® piping products in accordance with accepted standards for water-source heat pump applications and ASTM D 2774 *Underground Installation of Thermoplastic Pressure Piping*.
- When laid in a trench, ensure that the trench bottom is smooth and free from sharp or angular objects. Embedment soils must be free from refuse, organic material, cobbles, boulders, large rocks or stones, and frozen clods. Blocking must not be used to change pipe grade or to intermittently support pipe across excavated sections.
- When installed down-hole, such as in a vertical loop, be sure any ballast used to facilitate down-hole insertion does not impinge, gouge or cut into the pipe.

## Technical Information

### Heat Transfer

Heat transfer properties of various materials can be expressed by a "K-Value". A higher K-Value reflects greater heat transfer properties.

Material	K-Value, BTU/h-ft-°F
DriscoPlex <sup>®</sup> 5300 Climate Guard <sup>®</sup> PE 3608	0.225
PVC	0.087

**Table 1 Approximate Water Volume for 100 Feet of Pipe†**

Nominal Pipe Size	Gallons	Nominal Pipe Size	Gallons
3/4" IPS DR 11	2.93	3" IPS DR 11	32.57
1" IPS DR 11	4.60	4" IPS DR 11	53.84
1-1/4" IPS DR 11	7.33	6" IPS DR 15.5	133.47
1-1/2" IPS DR 11	9.60	8" IPS DR 15.5	226.17
2" IPS DR 11	15.00		

\* Approximate volume of water in U.S. gallons at 73°F for ASTM D 3035 nominal outside diameter and average wall thickness for pipe.

**Table 2 Climate Guard<sup>®</sup> 5300 Pressure Rating (psi) vs. Temperature (°F)‡**

Temp, °F	DR 15.5	SDR 11	SDR 9**
73	110	160	200
80	104	151	189
90	95	138	173
100	87	126	157
110	78	114	142
120	70	102	128
130	63	91	114
140	55	80	100

\* PE 3408 pressure ratings for water. PE 3408 HDB = 1600 psi at 73°F and 800 psi at 140°F. Intermediate temperature LTHS interpolated in accordance with PPI TN-18. \*\* Optional SDR 9 for Unicoil™.

**Table 3 Estimated Flow Properties for 100 Feet of Pipe - GPM, Pressure Drop (psi), Velocity (fps), Velocity (fps)†**

GPM	3/4" IPS DR 11		1" IPS DR 11		1-1/4" IPS DR 11		1-1/2" IPS DR 11		2" IPS DR 11		3" IPS DR 11		4" IPS DR 11		6" IPS DR 15.5		8" IPS DR 15.5	
	psi	fps	psi	fps	psi	fps	psi	fps	psi	fps	psi	fps	psi	fps	psi	fps	psi	fps
2	0.34	1.14	0.11	0.73	0.04	0.46	0.02	0.35	0.01	0.22								
3	0.73	1.71	0.24	1.09	0.08	0.68	0.04	0.52	0.01	0.33								
4	1.24	2.27	0.41	1.45	0.13	0.91	0.07	0.69	0.02	0.44								
5	1.87	2.84	0.63	1.81	0.20	1.14	0.10	0.87	0.04	0.56	0.01	0.26						
6	2.62	3.41	0.88	2.18	0.28	1.37	0.15	1.04	0.05	0.67	0.01	0.31						
7	3.48	3.98	1.17	2.54	0.38	1.59	0.19	1.22	0.07	0.78	0.01	0.36						
8	4.46	4.55	1.49	2.90	0.48	1.82	0.25	1.39	0.08	0.89	0.01	0.41						
9	5.54	5.12	1.85	3.26	0.60	2.05	0.31	1.56	0.10	1.00	0.02	0.46						
10	6.74	5.69	2.25	3.63	0.73	2.28	0.38	1.74	0.13	1.11	0.02	0.51	0.01	0.31				
12			3.16	4.35	1.02	2.73	0.53	2.08	0.18	1.33	0.03	0.61	0.01	0.37				
15			4.77	5.44	1.54	3.41	0.80	2.60	0.27	1.67	0.04	0.77	0.01	0.46				
18			6.69	6.53	2.15	4.10	1.12	3.13	0.38	2.00	0.06	0.92	0.02	0.56				
21					2.86	4.78	1.48	3.65	0.50	2.33	0.08	1.07	0.02	0.65				
24					3.66	5.46	1.90	4.17	0.64	2.67	0.10	1.23	0.03	0.74				
27					4.56	6.14	2.36	4.69	0.80	3.00	0.12	1.38	0.04	0.84				
30					5.54	6.83	2.87	5.21	0.97	3.33	0.15	1.54	0.04	0.93				
35					7.37	7.96	3.82	6.08	1.29	3.89	0.20	1.79	0.06	1.08	0.01	0.44		
40							4.89	6.95	1.65	4.45	0.25	2.05	0.07	1.24	0.01	0.50		
45							6.08	7.81	2.05	5.00	0.31	2.30	0.09	1.39	0.01	0.56		
50							7.39	8.68	2.49	5.56	0.38	2.56	0.11	1.55	0.01	0.62		
55									2.97	6.11	0.45	2.81	0.13	1.70	0.01	0.69		
60									3.49	6.67	0.53	3.07	0.16	1.86	0.02	0.75		
70									4.65	7.78	0.70	3.58	0.21	2.17	0.02	0.87	0.01	0.52
80									5.95	8.89	0.90	4.09	0.27	2.48	0.03	1.00	0.01	0.59
90									7.40	10.00	1.12	4.61	0.33	2.79	0.04	1.12	0.01	0.66
100											1.36	5.12	0.40	3.10	0.04	1.25	0.01	0.84
110											1.63	5.63	0.48	3.41	0.05	1.37	0.01	0.81
120											1.91	6.14	0.56	3.72	0.06	1.50	0.02	0.88
130											2.21	6.65	0.65	4.02	0.07	1.82	0.02	0.96

†U.S. gallons of water. ASTM D 3035 nominal outside diameter & average wall thickness. Pressure drop estimated using Hazen-Williams C = 150 for water at 60°F.

---

## CONTACT INFORMATION:

**PERFORMANCE PIPE**, a division of  
Chevron Phillips Chemical Company  
LP  
PO Box 269006  
Plano, TX 75026-9006

To secure product information  
or technical assistance:

Phone: 800-527-0662  
Fax: 972-599-7348  
www.performancepipe.com

---

## PERFORMANCE PIPE PLANTS

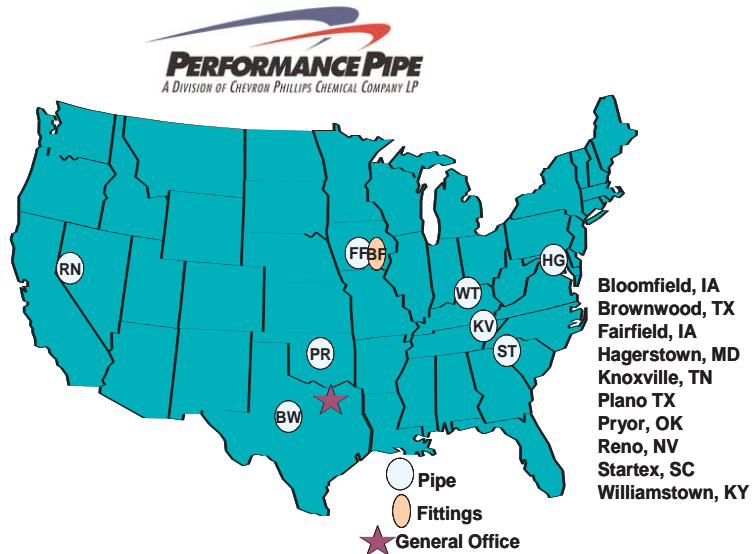

Strategically Located Plants  
To Better Serve Your Needs!



## PERFORMANCE PIPE Product Literature

### Technical Notes & Bulletins:

- PP 102-DS DRISCOPLEX® 5300 Series Climate Guard® Geothermal Piping System Data Sheet
- PP 652 Model Specifications for DRISCOPLEX® 5300 Climate Guard® System
- PP 653 Warranty
- PP 655 Submittal

Visit [www.performancepipe.com](http://www.performancepipe.com) for the latest literature.

## Model Specifications

# DRISCOPLEX<sup>®</sup> 5300 Series Climate Guard<sup>®</sup> Systems for Geothermal Applications

**Scope:** This specification designates requirements for geothermal (ground source heat pump) pipe and fittings.

**Material:** All pipe and heat fused materials shall be manufactured from high density, extra-high molecular weight PE 3608 material. The material shall have a 1600 psi Hydrostatic Design Basis at 73.4 degrees F per ASTM D-2837, and shall be listed in PPI TR4 as a PE3608 piping formulation. The material shall have a cell classification of 345464C or greater as specified in ASTM D-3350.

**Pipe:** The extruded pipe shall conform to the specifications and requirements of ASTM D-3035. Clean rework material from the manufacturer's own production may be used provided the pipe or fittings meet all requirements of this specification. Recycled and reclaimed materials from outside the manufacturer's plant shall not be used. Pipe used for vertical bore applications shall include a fused, single, piece, injection molded U-bend Polywing fitting. The approved pipe product is DRISCOPLEX<sup>®</sup> 5300 Series Climate Guard<sup>®</sup> Pipe from Performance Pipe.

**Fittings:** Molded fittings shall be manufactured to the specifications and requirements of ASTM D-2683 for socket fittings, ASTM D-3261 for butt fittings. All fittings shall be rated for pressure service equivalent to SDR 11 PE 3608 pipe.

The approved fittings are DRISCOPLEX<sup>®</sup> 5300 Series Climate Guard<sup>®</sup> Systems from Performance Pipe.

**Joints:** Where heat fusion is used for joining, persons performing heat fusion shall be qualified in accordance with the manufacturer's recommended fusion joining procedures. Electrofusion and mechanical joints shall be made in accordance with the fitting manufacturer's instructions.

**NOTICE.** This publication is for informational purposes and is intended for use as a reference guide. It should not be used in place of the advice of a professional engineer. This publication does not contain or confer any warranty or guarantee of any kind. Performance Pipe has made every reasonable effort towards the accuracy of the information contained in this publication, but it may not provide all necessary information, particularly with respect to special or unusual applications. This publication may be changed from time to time without notice. Contact Performance Pipe to ensure that you have the most current edition.

**Manufacturer:** The pipe and fittings manufacturer shall have in place a functional quality assurance program shall and be ISO (the International Organization for Standardization) Certified.

The approved manufacturer for pipe and fittings is Performance Pipe

**Marking:** Each pipe shall be durably marked with the manufacturer's name, nominal size, pressure rating, ASTM standard, material designation or cell classification number and date and location of manufacture. Coils shall be marked with footage marks at intervals no greater than two feet. Each fitting shall be identified with the manufacturer's name, nominal size, ASTM standard and lot number.

**Installation:** Construction and installation shall be in compliance with IGSHPA Standards and all applicable local, state and federal regulations. The Contractor shall observe all appropriate safety requirements in accordance with local, state and federal codes and regulations.

**Hydrotesting:** The completed system shall be hydrostatically tested at a pressure not greater than 150% of the pipe pressure rating in accordance with industry accepted hydrostatic leak testing procedures. Testing with compressed air or a compressed gas is prohibited.

**PERFORMANCE PIPE**, a division of  
Chevron Phillips Chemical Company LP  
PO Box 269006  
Plano, TX 75026-9006  
Phone: 1-800-527-0662  
Fax: 972-599-7348

Web:

[www.performancepipe.com](http://www.performancepipe.com)



PerformancePipe.com

# DRISCOPLEX® 5300 Climateguard® HDPE PIPE DATA SHEET

## DriscoPlex® 5300 Pipe meets or exceeds:

ASTM D3035  
ASTM D3350, cell classification PE345464C  
PPI TR-4 designation PE3608

## DriscoPlex® 5300 Pipe for:

Groundsource Heat Pumps, Icerink Piping, Snowmelt  
Iron Pipe Size OD (IPS) ¾" to 24"  
20', 40' and 50' Joints / Solid Black  
Coils available in various lengths in sizes through 6"  
UniCoils® available in ¾", 1" and 1 ¼"

NOMINAL PIPE PROPERTIES <sup>(1)</sup>	UNIT	TEST METHOD	VALUE
Density	gms / cm <sup>3</sup>	ASTM D1505	0.955 (black)
Melt Index (MI) Condition 190°C / 2.16kg	gms / 10 minutes	ASTM D1238	0.08
Hydrostatic Design Basis 73° F (23° C)	psi	ASTM D2837	1600
Hydrostatic Design Basis 140° F (60° C)	psi	ASTM D2837	800
Color: UV Stabilizer [C]	---	ASTM D3350	Min 2% Carbon Black
NOMINAL MATERIAL PROPERTIES <sup>(1) (2)</sup>	UNIT	TEST METHOD	VALUE
Flexural Modulus 2% Secant – 16:1 span: depth. 0.5 in / min.	psi	ASTM D790	>110,000
Tensile Strength at Yield	psi	ASTM D638 Type IV	3200
Elongation at Break 2 in / min., Type IV Bar	%	ASTM D638	>800
Elastic Modulus	psi	ASTM D638	>150,000
Hardness	Shore D	ASTM D2240	62
PENT	hrs	ASTM F1473	>100
Vicat Softening Temperature	°F	ASTM D1525	256
Brittleness Temperature	°F	ASTM D746	< -103
Thermal Expansion	in / in / °F	ASTM D696	1.0 x 10 <sup>-4</sup>

1. This is not a product specification and does not guarantee or establish specific minimum or maximum values or manufacturing tolerance for material or piping products to be supplied.
2. Values obtained from tests of specimens taken from piping product may vary from these typical values.

**When Performance Matters Rely on**  
*Performance Pipe*

Bulletin: PP111 / August 2009

© 2009 Chevron Phillips Chemical Company LP

Performance Pipe, a division of Chevron Phillips Chemical Company LP | 5085 W. Park Blvd | Suite 500 | Plano, TX 75093 | Phone: 800-527-0662 | Fax: 972-599-7348

This data sheet provides typical properties for Performance Pipe DriscoPlex® pipe and fittings. Before using this product, the user is advised and cautioned to make their own determination and assessment of the safety and suitability of the product for the specific use in question and is further advised against relying on the information contained herein as it may relate to any specific use or application. It is the ultimate responsibility of the user to ensure that the product is suited and the information is applicable to the user's specific application. Chevron Phillips Chemical Company LP does not make, and expressly disclaims, all warranties, including warranties of merchantability or fitness for a particular purpose, regardless of whether oral or written, express or implied, allegedly arising from any usage of any trade or from any course of dealing in connection with the use of information contained herein or the product itself. The user expressly assumes all risk and liability, whether based in contract, tort or otherwise, in connection with the use of the information contained herein or the product itself. Further, information contained herein is given without reference to any intellectual property issues, as well as federal, state or local laws which may be encountered in the use thereof. Such questions should be investigated by the user. The data sheet may change periodically. Visit [www.PerformancePipe.com](http://www.PerformancePipe.com) for the most current data sheet.



# Material Safety Data Sheet

## SECTION 1 PRODUCT AND COMPANY IDENTIFICATION

### Performance Pipe (PE Pipe and Fittings: Various Colors)

**Product Use:** Conveyance of liquids, gases and other media.

**Synonyms:** Polyethylene Plastic DriscoPlex® Pipe and Fittings

**Product CAS No.:** Mixture

**Company Identification:**

Performance Pipe, A Division of  
Chevron Phillips Chemical Company LP  
5085 W Park Blvd, Ste 500  
PlanoTX 75093

**Product Information:**

MSDS Requests: 1 - (800) 852-5530  
Technical Information: 1 - (800) 527-0662  
Responsible Party: Product Safety Group  
Email:msds@cpchem.com

Chevron Phillips Chemicals International N.V.  
Brusselsesteenweg 355  
B-3090 Overijse  
Belgium

**24-Hour Emergency Telephone Numbers:** HEALTH:Chevron Phillips Emergency Information Center 866.442.9628 (North America) and 1.832.813.4984 (International)

TRANSPORTATION: North America: CHEMTREC 800.424.9300 or 703.527.3887  
ASIA: +1.703.527.3887  
EUROPE: BIG .32.14.584545 (phone) or .32.14.583516 (telefax)  
SOUTH AMERICA SOS-Cotec Inside Brazil: 0800.111.767  
Outside Brazil: 55.19.3467.1600

## SECTION 2 HAZARDS IDENTIFICATION

\*\*\*\*\*  
**EMERGENCY OVERVIEW**

Colored plastic (various colors)

**NFPA RATINGS:** Health: 0 Flammability: 0 Reactivity: 0

**GHS Classification and Labeling:**

Not hazardous. No hazards have been determined using GHS criteria.

\*\*\*\*\*

**IMMEDIATE HEALTH EFFECTS:**

**Eye:** If this material is heated, thermal burns may result from eye contact. Not expected to cause prolonged or significant eye irritation.

**Skin:** If this material is heated, thermal burns may result from skin contact. Contact with the skin is not expected to cause prolonged or significant irritation. Contact with the skin is not expected to cause an allergic skin response. Thermal burns to the skin: may include pain or feeling of heat, discoloration, swelling, and blistering.

**Ingestion:** Not expected to be harmful if swallowed.

**Inhalation:** Not expected to be harmful if inhaled. If this material is heated, fumes may be unpleasant and produce nausea and irritation of the upper respiratory tract.

**SECTION 3 COMPOSITION/ INFORMATION ON INGREDIENTS**

COMPONENT	CAS NUMBER	AMOUNT	EINECS / ELINCS	SYM	R-Phrases
Polyethylene	9002-88-4	> 96 % weight	EXEMPT	NA	NA
Polyethylene Hexene Copolymer	25213-02-9	> 96 % weight	EXEMPT	NA	NA
Polyethylene Butene Copolymer	25087-34-7	> 96 % weight	NA	NA	NA
May Include: Carbon Black	1333-86-4	0 - 4 % weight	215-609-9	NA	NA
May Include: Lead Chromate Pigment	1344-37-2	0 - 1 % weight	215-693-7	T, N	R62, R50/53, R40, R33, R61

**Occupational Exposure Limits:**

Component	Limit	TWA	STEL	Ceiling / Peak	Notation
May Include: Carbon Black	ACGIH	3.5 mg/m3	NA	NA	NA
May Include: Carbon Black	German MAK	6 mg/m3	NA	NA	NA
May Include: Carbon Black	OSHA PEL	3.5 mg/m3	NA	NA	NA
May Include: Lead Chromate Pigment	ACGIH	.01 mg/m3	NA	NA	NA
May Include: Lead Chromate Pigment	German MAK	.1 mg/m3	NA	4	NA
May Include: Lead Chromate Pigment	OSHA SP	.05 mg/m3	NA	NA	NA
Polyethylene	ACGIH	3 mg/m3	NA	NA	NA
Polyethylene	German MAK	6 mg/m3	NA	NA	NA
Polyethylene Butene Copolymer	ACGIH	Not Established	NA	NA	NA
Polyethylene Hexene Copolymer	ACGIH	Not Established	NA	NA	NA

**SECTION 4 FIRST AID MEASURES**

**Eye:** If heated material should splash into eyes, flush eyes immediately with fresh water for 15 minutes while holding the eyelids open. Remove contact lenses, if worn. Get immediate medical attention.

**Skin:** If the hot material gets on skin, quickly cool in water. See a doctor for extensive burns. Do not try to peel the

solidified material from the skin or use solvents or thinners to dissolve it. The use of vegetable oil, mineral oil, or petroleum jelly is recommended for removal of this material from the skin.

**Ingestion:** If swallowed, do not induce vomiting. Give the person a glass of water or milk to drink and get immediate medical attention. Never give anything by mouth to an unconscious person.

**Inhalation:** Move the exposed person to fresh air. If not breathing, give artificial respiration. If breathing is difficult, give oxygen. Get medical attention if breathing difficulties continue.

## SECTION 5 FIRE FIGHTING MEASURES

### FIRE CLASSIFICATION:

Classification (29 CFR 1910.1200): Not flammable or combustible. This material will burn although it is not easily ignited.

**NFPA RATINGS:** Health: 0 Flammability: 0 Reactivity: 0

### FLAMMABLE PROPERTIES:

**Flashpoint:** NA

**Autoignition:** NA

**Flammability (Explosive) Limits (% by volume in air):** Lower: NA Upper: NA

**EXTINGUISHING MEDIA:** Use water fog, foam, dry chemical or carbon dioxide (CO<sub>2</sub>) to extinguish flames.

### PROTECTION OF FIRE FIGHTERS:

**Fire Fighting Instructions:** Material will not burn unless preheated. Clear fire area of all non-emergency personnel. Only enter confined fire space with full gear, including a positive pressure, NIOSH-approved, self-contained breathing apparatus. Cool surrounding equipment, fire-exposed containers and structures with water. Container areas exposed to direct flame contact should be cooled with large quantities of water (500 gallons water per minute flame impingement exposure) to prevent weakening of container structure. If possible, water should be applied as a spray from a fogging nozzle since this is a surface burning material. The application of high velocity water will spread the burning surface layer. For fires involving this material, do not enter any enclosed or confined fire space without proper protective equipment, including self-contained breathing apparatus.

**Combustion Products:** Incomplete combustion can also produce formaldehyde. Normal combustion forms carbon dioxide, water vapor and may produce carbon monoxide, original monomer, other hydrocarbons and hydrocarbon oxidation products, depending on temperature and air availability. Combustion may form: Carbon Dioxide, Carbon Monoxide

## SECTION 6 ACCIDENTAL RELEASE MEASURES

**Protective Measures:** Eliminate all sources of ignition in vicinity of spilled material.

**Spill Management:** If heated material is spilled, allow it to cool before proceeding with disposal methods.

**Reporting:** U.S.A. regulations may require reporting spills of this material that could reach any surface waters. Report spills to local authorities and/or the National Response Center at (800) 424-8802 as appropriate or required.

## SECTION 7 HANDLING AND STORAGE

**READ AND OBSERVE ALL PRECAUTIONS ON PRODUCT LABEL . REFER TO PRODUCT LABEL OR MANUFACTURERS TECHNICAL BULLETINS FOR THE PROPER USE AND HANDLING OF THIS MATERIAL .**

**Precautionary Measures:** Avoid contact of heated material with eyes, skin, and clothing. Avoid breathing vapor or fumes from heated material.

**Unusual Handling Hazards:** Potentially toxic/irritating fumes may be evolved from heated material. At temperatures (>350°F, >177°C), polyethylenes can release vapors and gases, which are irritating to the mucous membranes of the eyes, mouth, throat, and lungs. These substances may include acetaldehyde, acetone, acetic acid, formic acid,

formaldehyde and acrolein. Based on animal data and limited epidemiological evidence, NTP, IARC (2A), and OSHA have listed formaldehyde as a probable human carcinogen. Following all recommendations within this MSDS should minimize exposure to thermal processing emissions.

**SECTION 8 EXPOSURE CONTROLS/PERSONAL PROTECTION**

**GENERAL CONSIDERATIONS:**

Consider the potential hazards of this material (see Section 3), applicable exposure limits, job activities, and other substances in the work place when designing engineering controls and selecting personal protective equipment. If engineering controls or work practices are not adequate to prevent exposure to harmful levels of this material, the personal protective equipment listed below is recommended. The user should read and understand all instructions and limitations supplied with the equipment since protection is usually provided for a limited time or under certain circumstances.

**ENGINEERING CONTROLS:**

If heated material generates vapor or fumes, use process enclosures, local exhaust ventilation, or other engineering controls to control exposure.

**PERSONAL PROTECTIVE EQUIPMENT:**

**Eye/Face Protection:** Wear eye protection such as safety glasses, chemical goggles, or faceshields if engineering controls or work practices are not adequate to prevent eye contact. If this material is heated, wear chemical goggles or safety glasses and a face shield.

**Skin Protection:** If this material is heated, wear insulated clothing to prevent skin contact if engineering controls or work practices are not adequate to prevent skin contact.

**Respiratory Protection:** If user operations generate harmful levels of airborne material that is not adequately controlled by ventilation, wear a NIOSH approved respirator that provides adequate protection. Use the following elements for air-purifying respirators: Organic Vapor and Formaldehyde.

**Occupational Exposure Limits:**

Component	Limit	TWA	STEL	Ceiling / Peak	Notation
May Include: Carbon Black	ACGIH	3.5 mg/m3	NA	NA	NA
May Include: Carbon Black	German MAK	6 mg/m3	NA	NA	NA
May Include: Carbon Black	OSHA PEL	3.5 mg/m3	NA	NA	NA
May Include: Lead Chromate Pigment	ACGIH	.01 mg/m3	NA	NA	NA
May Include: Lead Chromate Pigment	German MAK	.1 mg/m3	NA	4	NA
May Include: Lead Chromate Pigment	OSHA SP	.05 mg/m3	NA	NA	NA
Polyethylene	ACGIH	3 mg/m3	NA	NA	NA
Polyethylene	German MAK	6 mg/m3	NA	NA	NA
Polyethylene Butene Copolymer	ACGIH	Not Established	NA	NA	NA
Polyethylene Hexene Copolymer	ACGIH	Not Established	NA	NA	NA

**SECTION 9 PHYSICAL AND CHEMICAL PROPERTIES**

**Appearance and Odor:** Colored plastic (various colors)

**Autoignition:** NA

**Boiling Point:** NA

**Density:** 0.91 - 0.97 g/cm3

**Evaporation Rate:** NDA

**Flammability (Explosive) Limits (% by volume in air):** Lower: NA Upper: NA

**Flashpoint:** NA  
**Molecular Formula:** Mixture  
**Molecular Weight:** NA  
**Melting Point:** 100°C (212°F) - 135°C (275°F)  
**Octanol / Water Partition Coefficient: log-Kow:** NDA  
**pH:** NA  
**Pour Point:** NDA  
**Solubility (in water):** Insoluble in water.  
**Specific Gravity:** 0.91 - 1.02  
**Vapor Pressure:** NA  
**Vapor Density (AIR=1):** NA  
**Viscosity:** NDA  
**Percent Volatile:** NDA

## SECTION 10 STABILITY AND REACTIVITY

**Chemical Stability:** This material is considered stable under normal ambient and anticipated storage and handling conditions of temperature and pressure.

**Conditions to Avoid:** heating above recommended processing temperature

**Incompatibility With Other Materials:** None.

**Hazardous Decomposition Products:** Carbon Oxides.

**Hazardous Polymerization:** Hazardous polymerization will not occur.

## SECTION 11 TOXICOLOGICAL INFORMATION

### IMMEDIATE HEALTH EFFECTS:

**Acute Oral Toxicity:** LD50 / rat / 7950 mg/kg

**Acute Dermal Toxicity:** LD50 / not known

**Acute Inhalation Toxicity:** LC50 / not known

**Eye Irritation:** Polyethylene: This material is not expected to be irritating to the eyes.

**Skin Irritation:** This material is not expected to be irritating to the skin.

**Sensitization:** Dermal - not a sensitizer / human

### ADDITIONAL TOXICOLOGY INFORMATION:

This product contains POLYMERIZED OLEFINS.

During thermal processing (>350°F, >177°C) polyolefins can release vapors and gases (aldehydes, ketones and organic acids) which are irritating to the mucous membranes of the eyes, mouth, throat, and lungs. Generally these irritant effects are all transitory. However, prolonged exposure to irritating off-gases can lead to pulmonary edema. Formaldehyde (an aldehyde) has been classified as a probable human carcinogen by NTP, IARC (2A), and OSHA based on animal data and limited epidemiological evidence. Pigments containing carbon black, lead chromate, nickel, antimony, or titanium compounds may have been incorporated into this product. The International Agency for Research on Cancer (IARC) has classified carbon black as a Group 2B carcinogen (possibly carcinogenic to humans) based on sufficient evidence in animals and inadequate evidence in humans. However, the pigments in this product are bound in a polymer matrix which severely limits its extractability, bioavailability and toxicity. The lead chromate pigment is also silica-encapsulated as well as bound in the polymer matrix. None of these pigments is likely to cause adverse health effects under recommended conditions of use.

## SECTION 12 ECOLOGICAL INFORMATION

**ECOTOXICITY:**

This material is not expected to be harmful to aquatic organisms.

**ENVIRONMENTAL FATE:**

This material is not expected to be readily biodegradable.

**SECTION 13 DISPOSAL CONSIDERATIONS**

Use material for its intended purpose or recycle if possible. This material as manufactured is a non hazardous waste but may be contaminated upon use. If this material must be discarded, depending on its use and application, it may meet the criteria of a hazardous waste as defined by the US EPA under RCRA (40 CFR 261) or other State and local regulations. Measurement of certain physical properties and analysis for regulated components may be necessary to make accurate determinations. If this material is subsequently classified as a hazardous waste, federal law requires disposal at a permitted hazardous waste disposal facility.

**SECTION 14 TRANSPORT INFORMATION**

The shipping descriptions shown here are for bulk shipments only, and may not apply to shipments in non-bulk packages (see regulatory definition). Consult the appropriate domestic or international mode- specific and quantity- specific Dangerous Goods Regulations for additional shipping description requirements (e.g., technical name or names, etc.) Therefore, the information shown here, may not always agree with the bill of lading shipping description for the material. Flashpoints for the material may vary slightly between the MSDS and the bill of lading.

**Shipping Descriptions per regulatory authority.****US DOT**

NOT REGULATED AS A HAZARDOUS MATERIAL OR DANGEROUS GOODS FOR TRANSPORTATION

**ICAO / IATA**

NOT REGULATED AS A HAZARDOUS MATERIAL OR DANGEROUS GOODS FOR TRANSPORTATION

**IMO / IMDG**

NOT REGULATED AS A HAZARDOUS MATERIAL OR DANGEROUS GOODS FOR TRANSPORTATION

**RID / ADR**

NOT REGULATED AS A HAZARDOUS MATERIAL OR DANGEROUS GOODS FOR TRANSPORTATION

**SECTION 15 REGULATORY INFORMATION****SARA 311/312 CATEGORIES:**

- |                                       |    |
|---------------------------------------|----|
| 1. Immediate (Acute) Health Effects:  | NO |
| 2. Delayed (Chronic) Health Effects:  | NO |
| 3. Fire Hazard:                       | NO |
| 4. Sudden Release of Pressure Hazard: | NO |
| 5. Reactivity Hazard:                 | NO |

**REGULATORY LISTS SEARCHED:**

01 = CA Prop 65	17 = FDA 178	33 = -
02 = LA RTK	18 = FDA 179	34 = -
03 = MA RTK	19 = FDA 180	35 = -
04 =MN Hazardous Substance	20 = FDA 181	36 = -
05 =NJ RTK	21 = FDA 182	37 = SARA Section 302
06 = PA RTK	22 = FDA 184	38 = SARA Section 313
07 = -	23 = FDA 186	39 = TSCA 12 (b)
08 = -	24 = FDA 189	40 = TSCA Section 4
09 = CWA Section 311	25 = IARC Group 1	41 = TSCA Section 5(a)
10 =DOT Marine Pollutant	26 = IARC Group 2A	42 = TSCA Section 8(a) CAIR
11 = FDA 172	27 = IARC Group 2B	43 = TSCA Section 8(a) PAIR
12 = FDA 173	28 = IARC Group 3	44 = TSCA Section 8(d)
13 = FDA 174	29 = IARC Group 4	45 = WHIMS - IDL
14 = FDA 175	30 = NTP Carcinogen	46 = Germany D TAL
15 = FDA 176	31 = OSHA Carcinogen	47 = Germany WKG
16 = FDA 177	32 = OSHA Highly Hazardous	48 = DEA List 1
		49 = DEA List 2

**The following components of this material are found on the regulatory lists indicated.**

Polyethylene	4
May Include: Carbon Black	1, 3, 4, 5, 6, 27, 45
May Include: Lead Chromate Pigment	1, 3, 4, 5, 6, 25, 26, 30, 38, 39, 45, 46

**WHMIS CLASSIFICATION:**

This product is not considered a controlled product according to the criteria of the Canadian Controlled Products Regulations.

**CHEMICAL INVENTORY LISTINGS:**

<b>AUSTRALIA</b>	YES (AUS)
<b>CANADA</b>	YES (DSL)
<b>CHINA</b>	YES (IECSC)
<b>EUROPEAN UNION</b>	NO - Exempt (EINECS/ELINCS)
<b>JAPAN</b>	YES (ENCS)
<b>KOREA</b>	YES (ECL)
<b>PHILIPPINES</b>	YES (PICCS)
<b>UNITED STATES</b>	YES (TSCA)

**EU LABELING:**

**Symbols:**

NA - Not Applicable

**SECTION 16 OTHER INFORMATION**

**NFPA RATINGS:** Health: 0 Flammability: 0 Reactivity: 0 Special: NA

(0-Least, 1-Slight, 2-Moderate, 3-High, 4-Extreme, PPE:- Personal Protection Equipment Index recommendation, \*-Chronic Effect Indicator). These values are obtained using the guidelines or published evaluations prepared by the National Fire Protection Association (NFPA).

**REVISION STATEMENT:** This revision updates all sections of the MSDS please review.

**ABBREVIATIONS THAT MAY HAVE BEEN USED IN THIS DOCUMENT:**

TLV	- Threshold Limit Value	TWA	- Time Weighted Average
STEL	- Short-term Exposure Limit	PEL	- Permissible Exposure Limit
ACGIH	- American Conference of Government Industrial Hygienists	OSHA	- Occupational Safety & Health Administration
NIOSH	- National Institute for Occupational Safety & Health	NFPA	- National Fire Protection Agency
WHMIS	- Workplace Hazardous Materials Information System	IARC	- Intl. Agency for Research on Cancer
EINECS	- European Inventory of existing Commercial Chemical Substances	RCRA	- Resource Conservation Recovery Act
SARA	- Superfund Amendments and Reauthorization Act.	TSCA	- Toxic Substance Control Act
EC50	- Effective Concentration	LC50	- Lethal Concentration
LD50	- Lethal Dose	CAS	- Chemical Abstract Service
NDA	- No Data Available	NA	- Not Applicable
<=	- Less Than or Equal To	>=	- Greater Than or Equal To
CNS	- Central Nervous System	MAK	- Germany Maximum Concentration Values

**This data sheet is prepared according to the latest adaptation of the EEC Guideline 67/548.**

**This data sheet is prepared according to the OSHA Hazard Communication Standard (29 CFR 1910.1200).**

**This data sheet is prepared according to the ANSI MSDS Standard (Z400.1).**

**This data sheet was prepared by EHS Product Stewardship Group, Chevron Phillips Chemical Company LP, 10001 Six Pines Drive, The Woodlands, TX 77380.**

**This data sheet is prepared according to the Globally Harmonized System (GHS).**

**The above information is based on the data of which we are aware and is believed to be correct as of the date hereof. Since this information may be applied under conditions beyond our control and with which we may be unfamiliar and since data made available subsequent to the date hereof may suggest modifications of the information, we do not assume any responsibility for the results of its use. This information is furnished upon condition that the person receiving it shall make his own determination of the suitability of the material for his particular purpose.**

# TechData

## PRODUCT SPECIFICATION SHEET

The Viega logo consists of the word "viega" in a lowercase, sans-serif font, colored yellow, set against a black rectangular background. Below this black rectangle is a solid yellow horizontal bar.

### **ProGeo High Density Polyethylene Socket Heat Fusion Fittings For Water Source Earth-Coupled Heat Pump Systems**

#### **Scope**

This product specification designates the requirements for ProGeo high density polyethylene (HDPE) socket heat fusion fittings to be used as connections for Iron Pipe Size outside diameter (IPS-OD) controlled HDPE pipe in  $\frac{3}{4}$ ", 1", 1  $\frac{1}{4}$ ", 1  $\frac{1}{2}$ ", and 2" sizes.

#### **Materials**

ProGeo HDPE socket heat fusion fittings are manufactured from a bimodal polyethylene resin PE4710 with a cell classification, PE345564C per ASTM D-3350. This high performance resin exhibits enhanced performance properties including superior Slow Crack Growth (SCG) resistance plus improved tensile strength and modulus.

ProGeo socket fusion by metallic adapter fittings are manufactured using machined components of brass alloy B360 per ASTM B-16.

#### **Recommended Uses**

ProGeo socket heat fusion fittings are intended and recommended for use in open or closed loop, water source earth coupled heat pump systems installed with IPS-OD, HDPE pipe manufactured to a minimum pressure rating of SDR11 or Schedule 40.

#### **Handling and Installation**

ProGeo socket heat fusion fittings shall be installed in accordance with industry accepted and approved procedures, applicable code requirements and current assembly guidelines available from Viega, LLC. Prior to installation, ProGeo socket heat fusion fittings should be stored in a clean, dry location.



# ProGeo

## Couplers

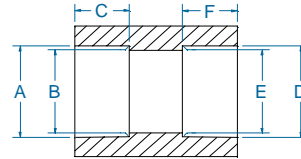

SAP NUMBER	DRAWING NUMBER	DIMENSIONS								
		A	B	C	D	E	F	G	H	I
657294	YFPC44	1.020 ±.008	1.012 +.008 -.012	.625 Min.	1.020 ±.008	1.012 +.008 -.012	.625 Min.			
657295	YFPC54	1.275 ±.008	1.267 +.008 -.012	.687 Min.	1.020 ±.008	1.012 +.008 -.012	.625 Min.			
657296	YFPC55	1.275 ±.008	1.267 +.008 -.012	.687 Min.	1.275 ±.008	1.267 +.008 -.012	.687 Min.			
657297	YFPC64	1.620±.008	1.612 +.008 -.016	.875 Min.	1.020 ±.008	1.012 +.008 -.012	.625 Min.			
657298	YFPC65	1.620±.008	1.612 +.008 -.016	.875 Min.	1.275 ±.008	1.267 +.008 -.012	.687 Min.			
657299	YFPC66	1.620±.008	1.612 +.008 -.016	.875 Min.	1.620±.008	1.612 +.008 -.016	.875 Min.			
657301	YFPC74	1.860±.010	1.849 +.010 -.020	.875 Min.	1.020 ±.008	1.012 +.008 -.012	.625 Min.			
657302	YFPC75	1.860±.010	1.849 +.010 -.020	.875 Min.	1.275 ±.008	1.267 +.008 -.012	.687 Min.			
657303	YFPC76	1.860±.010	1.849 +.010 -.020	.875 Min.	1.620±.008	1.612 +.008 -.016	.875 Min.			
657304	YFPC77	1.860±.010	1.849 +.010 -.020	.875 Min.	1.860±.010	1.849 +.010 -.020	.875 Min.			
657305	YFPC85	2.235±.010	2.324 +.010 -.020	.875 Min.	1.275 ±.008	1.267 +.008 -.012	.687 Min.			
657306	YFPC86	2.235±.010	2.324 +.010 -.020	.875 Min.	1.620±.008	1.612 +.008 -.016	.875 Min.			
657307	YFPC87	2.235±.010	2.324 +.010 -.020	.875 Min.	1.620±.008	1.612 +.008 -.016	.875 Min.			
657308	YFPC88	2.235±.010	2.324 +.010 -.020	.875 Min.	2.235±.010	2.324 +.010 -.020	.875 Min.			

## Caps

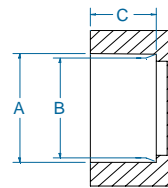

SAP NUMBER	DRAWING NUMBER	DIMENSIONS								
		A	B	C	D	E	F	G	H	I
657309	YFPCP4	1.020 ±.008	1.012 +.008 -.012	.625 Min.						
657310	YFPCP5	1.275 ±.008	1.267 +.008 -.012	.687 Min.						
657311	YFPCP6	1.620±.008	1.612 +.008 -.016	.875 Min.						
657312	YFPCP7	1.860±.010	1.849 +.010 -.020	.875 Min.						
657313	YFPCP8	2.235±.010	2.324 +.010 -.020	.875 Min.						



# ProGeo

## 90° Elbows

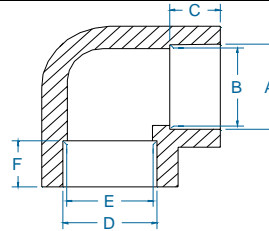

SAP NUMBER	DRAWING NUMBER	DIMENSIONS								
		A	B	C	D	E	F	G	H	I
657315	YFPE44	1.020 ±.008	1.012 +.008 -.012	.625 Min.	1.020 ±.008	1.012 +.008 -.012	.625 Min.			
657317	YFPE54	1.275 ±.008	1.267 +.008 -.012	.687 Min.	1.020 ±.008	1.012 +.008 -.012	.625 Min.			
657318	YFPE55	1.275 ±.008	1.267 +.008 -.012	.687 Min.	1.275 ±.008	1.267 +.008 -.012	.687 Min.			
	YFPE64	1.620±.008	1.612 +.008 -.016	.875 Min.	1.020 ±.008	1.012 +.008 -.012	.625 Min.			
657322	YFPE65	1.620±.008	1.612 +.008 -.016	.875 Min.	1.275 ±.008	1.267 +.008 -.012	.687 Min.			
657323	YFPE66	1.620±.008	1.612 +.008 -.016	.875 Min.	1.620±.008	1.612 +.008 -.016	.875 Min.			
657326	YFPE77	1.860±.010	1.849 +.010 -.020	.875 Min.	1.860±.010	1.849 +.010 -.020	.875 Min.			
657327	YFPE86	2.235±.010	2.324 +.010 -.020	.875 Min.	1.620±.008	1.612 +.008 -.016	.875 Min.			
657945	YFPE88	2.235±.010	2.324 +.010 -.020	.875 Min.	2.235±.010	2.324 +.010 -.020	.875 Min.			

## 90° U-Bend Elbows

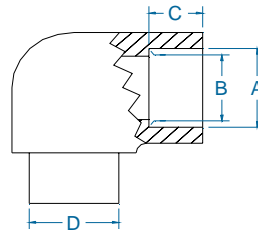

SAP NUMBER	DRAWING NUMBER	DIMENSIONS								
		A	B	C	D	E	F	G	H	I
657331	YFPEU44	1.020 ±.008	1.012 +.008 -.012	.625 Min.	3/4" PIPE STUB					
657332	YFPEU55	1.275 ±.008	1.267 +.008 -.012	.687 Min.	1" PIPE STUB					
657333	YFPEU66F	1.620±.008	1.612 +.008 -.016	.875 Min.	1 1/4" FEMALE					
657334	YFPEU66M	1.620±.008	1.612 +.008 -.016	.875 Min.	1 1/4" PIPE STUB					



# ProGeo

## Flanges

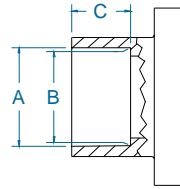

SAP NUMBER	DRAWING NUMBER	DIMENSIONS								
		A	B	C	D	E	F	G	H	I
657335	YFPF45	1.020 ±.008	1.012 +.008 -.012	.625 Min.	* SLIM FLANGE					
657337	YFPFF4	1.020 ±.008	1.012 +.008 -.012	.625 Min.						
657338	YFPFF5	1.275 ±.008	1.267 +.008 -.012	.687 Min.						
657340	YFPFF6	1.620±.008	1.612 +.008 -.016	.875 Min.						
657341	YFPFF8	2.235±.010	2.324 +.010 -.020	.875 Min.						

## Header Tees

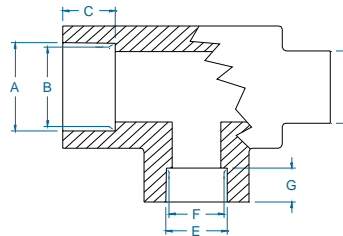

SAP NUMBER	DRAWING NUMBER	DIMENSIONS								
		A	B	C	D	E	F	G	H	I
657342	YFPFT554	1.275 ±.008	1.267 +.008 -.012	.687 Min.	1" PIPE STUB	1.020 ±.008	1.012 +.008 -.012	.625 Min.		
657343	YFPFT555	1.275 ±.008	1.267 +.008 -.012	.687 Min.	1" PIPE STUB	1.275 ±.008	1.267 +.008 -.012	.687 Min.		
657344	YFPFT654	1.620±.008	1.612 +.008 -.016	.875 Min.	1" PIPE STUB	1.020 ±.008	1.012 +.008 -.012	.625 Min.		
	YFPFT655	1.620±.008	1.612 +.008 -.016	.875 Min.	1" PIPE STUB	1.275 ±.008	1.267 +.008 -.012	.687 Min.		
657346	YFPFT664	1.620±.008	1.612 +.008 -.016	.875 Min.	1 1/4" PIPE STUB	1.020 ±.008	1.012 +.008 -.012	.625 Min.		
657347	YFPFT665	1.620±.008	1.612 +.008 -.016	.875 Min.	1 1/4" PIPE STUB	1.275 ±.008	1.267 +.008 -.012	.687 Min.		



# ProGeo

## Male Pipe Thread Adapters

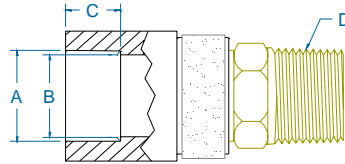

SAP NUMBER	DRAWING NUMBER	DIMENSIONS								
		A	B	C	D	E	F	G	H	I
657348	YFPMA44	1.020 ±.008	1.012 +.008 -.012	.625 Min.	3/4" MPT					
657349	YFPMA45	1.020 ±.008	1.012 +.008 -.012	.625 Min.	1" MPT					
657350	YFPMA54	1.275 ±.008	1.267 +.008 -.012	.687 Min.	3/4" MPT					
657351	YFPMA55	1.275 ±.008	1.267 +.008 -.012	.687 Min.	1" MPT					
657352	YFPMA64	1.620±.008	1.612 +.008 -.016	.875 Min.	3/4" MPT					
657353	YFPMA65	1.620±.008	1.612 +.008 -.016	.875 Min.	1" MPT					
657354	YFPMA66	1.620±.008	1.612 +.008 -.016	.875 Min.	1 1/4" MPT					
657355	YFPMA67	1.620±.008	1.612 +.008 -.016	.875 Min.	1 1/2" MPT					
657356	YFPMA77	1.860±.010	1.849 +.010 -.020	.875 Min.	1 1/2" MPT					
657357	YFPMA86	2.235±.010	2.324 +.010 -.020	.875 Min.	1 1/4" MPT					
657358	YFPMA87	2.235±.010	2.324 +.010 -.020	.875 Min.	1 1/2" MPT					
657359	YFPMA88	2.235±.010	2.324 +.010 -.020	.875 Min.	2" MPT					

## Male Nominal Thread Adapter Couplers

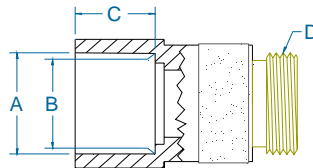

SAP NUMBER	DRAWING NUMBER	DIMENSIONS								
		A	B	C	D	E	F	G	H	I
657360	YFPMC45S	1.020 ±.008	1.012 +.008 -.012	.625 Min.	1" MNT					
	YFPMC55S	1.275 ±.008	1.267 +.008 -.012	.687 Min.	1" MNT					
657362	YFPMC56S	1.275 ±.008	1.267 +.008 -.012	.687 Min.	1 1/4" MNT					
657363	YFPMC65S	1.620±.008	1.612 +.008 -.016	.875 Min.	1" MNT					
657364	YFPMC66S	1.620±.008	1.612 +.008 -.016	.875 Min.	1 1/4" MNT					



# ProGeo

## 90° Male Adapter Elbows

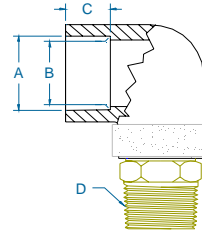

SAP NUMBER	DRAWING NUMBER	DIMENSIONS								
		A	B	C	D	E	F	G	H	I
657365	YFPME45S	1.020 ±.008	1.012 +.008 -.012	.625 Min.	1" MNT					
657368	YFPME55S	1.275 ±.008	1.267 +.008 -.012	.687 Min.	1" MNT					
657366	YFPME54	1.275 ±.008	1.267 +.008 -.012	.687 Min.	3/4" MPT					
657367	YFPME55	1.275 ±.008	1.267 +.008 -.012	.687 Min.	1" MPT					
657369	YFPME65	1.620±.008	1.612 +.008 -.016	.875 Min.	1" MPT					
657370	YFPME66	1.620±.008	1.612 +.008 -.016	.875 Min.	1 1/4" MPT					

## Male Thread Adapter Tees

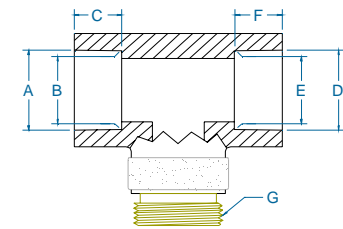
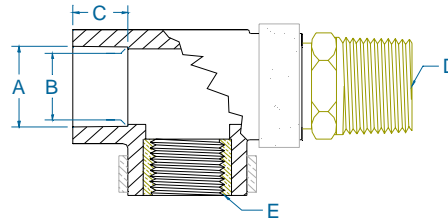
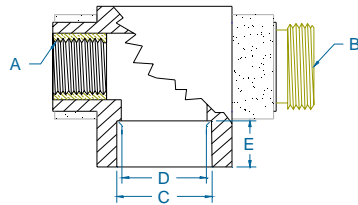

SAP NUMBER	DRAWING NUMBER	DIMENSIONS								
		A	B	C	D	E	F	G	H	I
657371	YFPMT355	1/2" FPT	1" MNT	1.275 ±.008	1.267 +.008 -.012	.687 Min.				
657372	YFPMT453	1.020 ±.008	1.012 +.008 -.012	.625 Min.	1" MNT	1/2" FPT				
657373	YFPMT553	1.275 ±.008	1.267 +.008 -.012	.687 Min.	1" MPT	1/2" FPT				
657374	YFPMT555S	1.275 ±.008	1.267 +.008 -.012	.687 Min.	1.275 ±.008	1.267 +.008 -.012	.687 Min.	1" MNT		
657375	YFPMT665S	1.620±.008	1.612 +.008 -.016	.875 Min.	1.620±.008	1.612 +.008 -.016	.875 Min.	1" MNT		



# ProGeo

## Female Thread Swivel Adapters

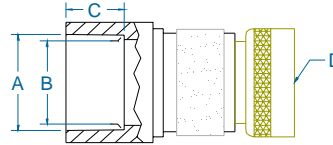

SAP NUMBER	DRAWING NUMBER	DIMENSIONS								
		A	B	C	D	E	F	G	H	I
657376	YFPSA45	1.020 ±.008	1.012 +.008 -.012	.625 Min.	1" FNT SWIVEL					
657377	YFPSA55	1.275 ±.008	1.267 +.008 -.012	.687 Min.	1" FNT SWIVEL					
657378	YFPSA65	1.620±.008	1.612 +.008 -.016	.875 Min.	1" FNT SWIVEL					

## Female Pipe Thread Adapters

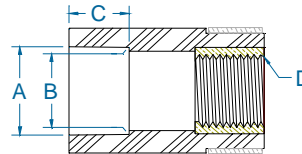

SAP NUMBER	DRAWING NUMBER	DIMENSIONS								
		A	B	C	D	E	F	G	H	I
657379	YFPSC42	1.020 ±.008	1.012 +.008 -.012	.625 Min.	1/4" FPT					
657380	YFPSC43	1.020 ±.008	1.012 +.008 -.012	.625 Min.	1/2" FPT					
657381	YFPSC52	1.275 ±.008	1.267 +.008 -.012	.687 Min.	1/4" FPT					
657382	YFPSC53	1.275 ±.008	1.267 +.008 -.012	.687 Min.	1/2" FPT					
657383	YFPSC54	1.275 ±.008	1.267 +.008 -.012	.687 Min.	3/4" FPT					

## Female Pipe Thread Adapter 90° Elbows

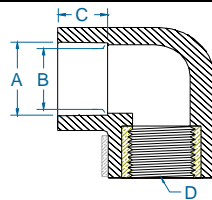

SAP NUMBER	DRAWING NUMBER	DIMENSIONS								
		A	B	C	D	E	F	G	H	I
657384	YFPSE43	1.020 ±.008	1.012 +.008 -.012	.625 Min.	1/2" FPT					
657385	YFPSE44	1.020 ±.008	1.012 +.008 -.012	.625 Min.	3/4" FPT					



# ProGeo

## Female Pipe Thread Adapter Tees

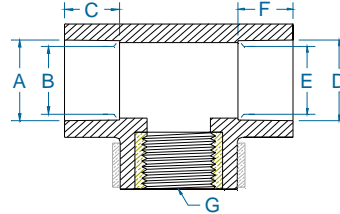

SAP NUMBER	DRAWING NUMBER	DIMENSIONS								
		A	B	C	D	E	F	G	H	I
657386	YFPST443	1.020 ±.008	1.012 +.008 -.012	.625 Min.	1.020 ±.008	1.012 +.008 -.012	.625 Min.	1/2" FPT		
657387	YFPST553	1.275 ±.008	1.267 +.008 -.012	.687 Min.	1.275 ±.008	1.267 +.008 -.012	.687 Min.	1/2" FPT		

## Tees

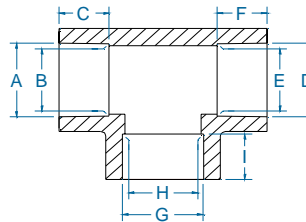

SAP NUMBER	DRAWING NUMBER	DIMENSIONS								
		A	B	C	D	E	F	G	H	I
657388	YFPT444	1.020 ±.008	1.012 +.008 -.012	.625 Min.	1.020 ±.008	1.012 +.008 -.012	.625 Min.	1.020 ±.008	1.012 +.008 -.012	.625 Min.
657389	YFPT554	1.275 ±.008	1.267 +.008 -.012	.687 Min.	1.275 ±.008	1.267 +.008 -.012	.687 Min.	1.020 ±.008	1.012 +.008 -.012	.625 Min.
657390	YFPT555	1.275 ±.008	1.267 +.008 -.012	.687 Min.	1.275 ±.008	1.267 +.008 -.012	.687 Min.	1.275 ±.008	1.267 +.008 -.012	.687 Min.
657391	YFPT644	1.620±.008	1.612 +.008 -.016	.875 Min.	1.020 ±.008	1.012 +.008 -.012	.625 Min.	1.020 ±.008	1.012 +.008 -.012	.625 Min.
657392	YFPT655	1.620±.008	1.612 +.008 -.016	.875 Min.	1.275 ±.008	1.267 +.008 -.012	.687 Min.	1.275 ±.008	1.267 +.008 -.012	.687 Min.
657393	YFPT664	1.620±.008	1.612 +.008 -.016	.875 Min.	1.620±.008	1.612 +.008 -.016	.875 Min.	1.020 ±.008	1.012 +.008 -.012	.625 Min.
657394	YFPT665	1.620±.008	1.612 +.008 -.016	.875 Min.	1.620±.008	1.612 +.008 -.016	.875 Min.	1.275 ±.008	1.267 +.008 -.012	.687 Min.
657396	YFPT666	1.620±.008	1.612 +.008 -.016	.875 Min.	1.620±.008	1.612 +.008 -.016	.875 Min.	1.620±.008	1.612 +.008 -.016	.875 Min.
657397	YFPT775	1.860±.010	1.849 +.010 -.020	.875 Min.	1.860±.010	1.849 +.010 -.020	.875 Min.	1.275 ±.008	1.267 +.008 -.012	.687 Min.
657398	YFPT777	1.860±.010	1.849 +.010 -.020	.875 Min.	1.860±.010	1.849 +.010 -.020	.875 Min.	1.860±.010	1.849 +.010 -.020	.875 Min.
657399	YFPT866	2.235±.010	2.324 +.010 -.020	.875 Min.	1.620±.008	1.612 +.008 -.016	.875 Min.	1.620±.008	1.612 +.008 -.016	.875 Min.
657400	YFPT884	2.235±.010	2.324 +.010 -.020	.875 Min.	2.235±.010	2.324 +.010 -.020	.875 Min.	1.020 ±.008	1.012 +.008 -.012	.625 Min.
657401	YFPT885	2.235±.010	2.324 +.010 -.020	.875 Min.	2.235±.010	2.324 +.010 -.020	.875 Min.	1.275 ±.008	1.267 +.008 -.012	.687 Min.
657402	YFPT886	2.235±.010	2.324 +.010 -.020	.875 Min.	2.235±.010	2.324 +.010 -.020	.875 Min.	1.620±.008	1.612 +.008 -.016	.875 Min.
657403	YFPT888	2.235±.010	2.324 +.010 -.020	.875 Min.	2.235±.010	2.324 +.010 -.020	.875 Min.	2.235±.010	2.324 +.010 -.020	.875 Min.



# Material Safety Data Sheet

The Dow Chemical Company

**Product Name:** Polyethylene 53050E High Density

**Issue Date:** 10/30/2008

**Print Date:** 31 Oct 2008

The Dow Chemical Company encourages and expects you to read and understand the entire (M)SDS, as there is important information throughout the document. We expect you to follow the precautions identified in this document unless your use conditions would necessitate other appropriate methods or actions.

## 1. Product and Company Identification

### Product Name

Polyethylene 53050E High Density

### COMPANY IDENTIFICATION

The Dow Chemical Company  
2030 Willard H. Dow Center  
Midland, MI 48674  
USA

Customer Information Number: 800-258-2436

### EMERGENCY TELEPHONE NUMBER

**24-Hour Emergency Contact:** 989-636-4400

**Local Emergency Contact:** 989-636-4400

## 2. Hazards Identification

### Emergency Overview

**Color:** White

**Physical State:** Pellets

**Odor:** Odorless

**Hazards of product:**

Slipping hazard.

### OSHA Hazard Communication Standard

This product is not a "Hazardous Chemical" as defined by the OSHA Hazard Communication Standard, 29 CFR 1910.1200.

### Potential Health Effects

**Eye Contact:** Solid or dust may cause irritation or corneal injury due to mechanical action. Elevated temperatures may generate vapor levels sufficient to cause eye irritation. Effects may include discomfort and redness.

**Skin Contact:** Prolonged contact is essentially nonirritating to skin. Mechanical injury only. Under normal processing conditions, material is heated to elevated temperatures; contact with the material may cause thermal burns.

®(TM)\*Trademark of The Dow Chemical Company ("Dow") or an affiliated company of Dow

**Skin Absorption:** No adverse effects anticipated by skin absorption.

**Inhalation:** No adverse effects are anticipated from single exposure to dust. Vapors/fumes released during thermal processing may cause respiratory irritation.

**Ingestion:** Very low toxicity if swallowed. Harmful effects not anticipated from swallowing small amounts. May cause choking if swallowed.

### 3. Composition Information

Component	CAS #	Amount
1-Butene, polymer with ethene	25087-34-7	> 99.0 %

### 4. First-aid measures

**Eye Contact:** Flush eyes thoroughly with water for several minutes. Remove contact lenses after the initial 1-2 minutes and continue flushing for several additional minutes. If effects occur, consult a physician, preferably an ophthalmologist.

**Skin Contact:** If molten material comes in contact with the skin, do not apply ice but cool under ice water or running stream of water. DO NOT attempt to remove the material from skin. Removal could result in severe tissue damage. Seek medical attention immediately.

**Inhalation:** Move person to fresh air; if effects occur, consult a physician.

**Ingestion:** If swallowed, seek medical attention. May cause gastrointestinal blockage. Do not give laxatives. Do not induce vomiting unless directed to do so by medical personnel.

**Notes to Physician:** If burn is present, treat as any thermal burn, after decontamination. No specific antidote. Treatment of exposure should be directed at the control of symptoms and the clinical condition of the patient.

### 5. Fire Fighting Measures

**Extinguishing Media:** Water fog or fine spray. Dry chemical fire extinguishers. Carbon dioxide fire extinguishers. Foam.

**Fire Fighting Procedures:** Keep people away. Isolate fire and deny unnecessary entry. Soak thoroughly with water to cool and prevent re-ignition. If material is molten, do not apply direct water stream. Use fine water spray or foam. Cool surroundings with water to localize fire zone. Hand held dry chemical or carbon dioxide extinguishers may be used for small fires.

**Special Protective Equipment for Firefighters:** Wear positive-pressure self-contained breathing apparatus (SCBA) and protective fire fighting clothing (includes fire fighting helmet, coat, trousers, boots, and gloves). If protective equipment is not available or not used, fight fire from a protected location or safe distance.

**Unusual Fire and Explosion Hazards:** Pneumatic conveying and other mechanical handling operations can generate combustible dust. To reduce the potential for dust explosions, do not permit dust to accumulate. Dense smoke is emitted when burned without sufficient oxygen.

**Hazardous Combustion Products:** During a fire, smoke may contain the original material in addition to combustion products of varying composition which may be toxic and/or irritating. Combustion products may include and are not limited to: Carbon monoxide. Carbon dioxide.

### 6. Accidental Release Measures

**Steps to be Taken if Material is Released or Spilled:** Contain spilled material if possible. Sweep up. Collect in suitable and properly labeled containers. See Section 13, Disposal Considerations, for additional information.

**Personal Precautions:** Spilled material may cause a slipping hazard. Use appropriate safety equipment. For additional information, refer to Section 8, Exposure Controls and Personal Protection.

**Environmental Precautions:** Prevent from entering into soil, ditches, sewers, waterways and/or groundwater. See Section 12, Ecological Information.

## 7. Handling and Storage

### Handling

**General Handling:** No smoking, open flames or sources of ignition in handling and storage area. Good housekeeping and controlling of dusts are necessary for safe handling of product. Avoid breathing process fumes. Use with adequate ventilation. When appropriate, unique handling information for containers can be found on the product label. Workers should be protected from the possibility of contact with molten resin. Do not get molten material in eyes, on skin or clothing. Pneumatic conveying and other mechanical handling operations can generate combustible dust. To reduce the potential for dust explosions, electrically bond and ground equipment and do not permit dust to accumulate. Dust can be ignited by static discharge.

### Storage

Store in accordance with good manufacturing practices.

## 8. Exposure Controls / Personal Protection

### Exposure Limits

None established

### Personal Protection

**Eye/Face Protection:** Use safety glasses. If there is a potential for exposure to particles which could cause eye discomfort, wear chemical goggles. If exposure causes eye discomfort, use a full-face respirator.

**Skin Protection:** No precautions other than clean body-covering clothing should be needed.

**Hand protection:** Chemical protective gloves should not be needed when handling this material. Consistent with general hygienic practice for any material, skin contact should be minimized. Use gloves to protect from mechanical injury. Selection of gloves will depend on the task. Use gloves with insulation for thermal protection, when needed.

**Respiratory Protection:** Respiratory protection should be worn when there is a potential to exceed the exposure limit requirements or guidelines. If there are no applicable exposure limit requirements or guidelines, wear respiratory protection when adverse effects, such as respiratory irritation or discomfort have been experienced, or where indicated by your risk assessment process. Use an approved air-purifying respirator when vapors are generated at increased temperatures or when dust or mist is present. The following should be effective types of air-purifying respirators: When dust/mist are present use a/an Particulate filter. When combinations of vapors, acids, or dusts/mists are present use a/an Organic vapor cartridge with a particulate pre-filter.

**Ingestion:** Use good personal hygiene. Do not consume or store food in the work area. Wash hands before smoking or eating.

### Engineering Controls

**Ventilation:** Use local exhaust ventilation, or other engineering controls to maintain airborne levels below exposure limit requirements or guidelines. If there are no applicable exposure limit requirements or guidelines, general ventilation should be sufficient for most operations. Local exhaust ventilation may be necessary for some operations.

## 9. Physical and Chemical Properties

**Physical State**  
**Color**

Pellets  
White

<b>Odor</b>	Odorless
<b>Flash Point - Closed Cup</b>	Not applicable
<b>Flammable Limits In Air</b>	<b>Lower:</b> Not applicable <b>Upper:</b> Not applicable
<b>Autoignition Temperature</b>	No test data available
<b>Vapor Pressure</b>	Not applicable
<b>Boiling Point (760 mmHg)</b>	Not applicable.
<b>Vapor Density (air = 1)</b>	Not applicable
<b>Specific Gravity (H<sub>2</sub>O = 1)</b>	0.83 - 0.97 <i>Supplier</i>
<b>Freezing Point</b>	Not applicable
<b>Melting Point</b>	<i>Supplier Varies</i>
<b>Solubility in Water (by weight)</b>	Negligible
<b>pH</b>	Not applicable
<b>Decomposition Temperature</b>	No test data available
<b>Partition coefficient, n-octanol/water (log Pow)</b>	No data available for this product.
<b>Kinematic Viscosity</b>	Not applicable

## 10. Stability and Reactivity

### Stability/Instability

Stable.

**Conditions to Avoid:** Exposure to elevated temperatures can cause product to decompose.

**Incompatible Materials:** None known.

### Hazardous Polymerization

Will not occur.

### Thermal Decomposition

Decomposition products depend upon temperature, air supply and the presence of other materials. Processing may release fumes and other decomposition products. At temperatures exceeding melt temperatures, polymer fragments can be released. Fumes can be irritating. Decomposition products can include and are not limited to: Aldehydes. Alcohols. Organic acids. Decomposition products can include trace amounts of: Hydrocarbons.

## 11. Toxicological Information

### Acute Toxicity

#### Ingestion

Estimated LD<sub>50</sub>, Rat > 5,000 mg/kg

#### Skin Absorption

Estimated LD<sub>50</sub>, Rabbit > 2,000 mg/kg

### Repeated Dose Toxicity

Additives are encapsulated in the product and are not expected to be released under normal processing conditions or foreseeable emergency.

### Chronic Toxicity and Carcinogenicity

No relevant information found.

### Developmental Toxicity

No relevant information found.

### Reproductive Toxicity

No relevant information found.

### Genetic Toxicology

No relevant information found.

## 12. Ecological Information

### ENVIRONMENTAL FATE

#### **Movement & Partitioning**

No bioconcentration is expected because of the relatively high molecular weight (MW greater than 1000). In the terrestrial environment, material is expected to remain in the soil. In the aquatic environment, material is expected to float.

#### **Persistence and Degradability**

This water-insoluble polymeric solid is expected to be inert in the environment. Surface photodegradation is expected with exposure to sunlight. No appreciable biodegradation is expected.

### ECOTOXICITY

Not expected to be acutely toxic, but material in pellet or bead form may mechanically cause adverse effects if ingested by waterfowl or aquatic life.

## 13. Disposal Considerations

DO NOT DUMP INTO ANY SEWERS, ON THE GROUND, OR INTO ANY BODY OF WATER. All disposal practices must be in compliance with all Federal, State/Provincial and local laws and regulations. Regulations may vary in different locations. Waste characterizations and compliance with applicable laws are the responsibility solely of the waste generator. AS YOUR SUPPLIER, WE HAVE NO CONTROL OVER THE MANAGEMENT PRACTICES OR MANUFACTURING PROCESSES OF PARTIES HANDLING OR USING THIS MATERIAL. THE INFORMATION PRESENTED HERE PERTAINS ONLY TO THE PRODUCT AS SHIPPED IN ITS INTENDED CONDITION AS DESCRIBED IN MSDS SECTION: Composition Information. FOR UNUSED & UNCONTAMINATED PRODUCT, the preferred options include sending to a licensed, permitted: Recycler. Reclaimer. Incinerator or other thermal destruction device. Landfill.

## 14. Transport Information

### **DOT Non-Bulk**

NOT REGULATED

### **DOT Bulk**

NOT REGULATED

### **IMDG**

NOT REGULATED

### **ICAO/IATA**

NOT REGULATED

*This information is not intended to convey all specific regulatory or operational requirements/information relating to this product. Additional transportation system information can be obtained through an authorized sales or customer service representative. It is the responsibility of the transporting organization to follow all applicable laws, regulations and rules relating to the transportation of the material.*

## 15. Regulatory Information

### OSHA Hazard Communication Standard

This product is not a "Hazardous Chemical" as defined by the OSHA Hazard Communication Standard, 29 CFR 1910.1200.

### Superfund Amendments and Reauthorization Act of 1986 Title III (Emergency Planning and Community Right-to-Know Act of 1986) Sections 311 and 312

Immediate (Acute) Health Hazard	No
Delayed (Chronic) Health Hazard	No
Fire Hazard	No
Reactive Hazard	No
Sudden Release of Pressure Hazard	No

### Superfund Amendments and Reauthorization Act of 1986 Title III (Emergency Planning and Community Right-to-Know Act of 1986) Section 313

To the best of our knowledge, this product does not contain chemicals at levels which require reporting under this statute.

### Pennsylvania (Worker and Community Right-To-Know Act): Pennsylvania Hazardous Substances List and/or Pennsylvania Environmental Hazardous Substance List:

To the best of our knowledge, this product does not contain chemicals at levels which require reporting under this statute.

### Pennsylvania (Worker and Community Right-To-Know Act): Pennsylvania Special Hazardous Substances List:

To the best of our knowledge, this product does not contain chemicals at levels which require reporting under this statute.

### California Proposition 65 (Safe Drinking Water and Toxic Enforcement Act of 1986)

This product contains no listed substances known to the State of California to cause cancer, birth defects or other reproductive harm, at levels which would require a warning under the statute.

### US. Toxic Substances Control Act

All components of this product are on the TSCA Inventory or are exempt from TSCA Inventory requirements under 40 CFR 720.30

### CEPA - Domestic Substances List (DSL)

All substances contained in this product are listed on the Canadian Domestic Substances List (DSL) or are not required to be listed.

## 16. Other Information

### Recommended Uses and Restrictions

A polyethylene plastic - For industrial conversion as a raw material for manufacture of articles or goods. We recommend that you use this product in a manner consistent with the listed use. If your intended use is not consistent with the stated use, please contact your sales or technical service representative.

### Revision

Identification Number: 50737 / 1001 / Issue Date 10/30/2008 / Version: 2.1

Most recent revision(s) are noted by the bold, double bars in left-hand margin throughout this document.

### Legend

N/A	Not available
-----	---------------

---

W/W	Weight/Weight
OEL	Occupational Exposure Limit
STEL	Short Term Exposure Limit
TWA	Time Weighted Average
ACGIH	American Conference of Governmental Industrial Hygienists, Inc.
DOW IHG	Dow Industrial Hygiene Guideline
WEEL	Workplace Environmental Exposure Level
HAZ_DES	Hazard Designation
Action Level	A value set by OSHA that is lower than the PEL which will trigger the need for activities such as exposure monitoring and medical surveillance if exceeded.

*The Dow Chemical Company urges each customer or recipient of this (M)SDS to study it carefully and consult appropriate expertise, as necessary or appropriate, to become aware of and understand the data contained in this (M)SDS and any hazards associated with the product. The information herein is provided in good faith and believed to be accurate as of the effective date shown above. However, no warranty, express or implied, is given. Regulatory requirements are subject to change and may differ between various locations. It is the buyer's/user's responsibility to ensure that his activities comply with all federal, state, provincial or local laws. The information presented here pertains only to the product as shipped. Since conditions for use of the product are not under the control of the manufacturer, it is the buyer's/user's duty to determine the conditions necessary for the safe use of this product. Due to the proliferation of sources for information such as manufacturer-specific (M)SDSs, we are not and cannot be responsible for (M)SDSs obtained from any source other than ourselves. If you have obtained an (M)SDS from another source or if you are not sure that the (M)SDS you have is current, please contact us for the most current version.*



**PRESSURE RATING:**

PE4710 Socket Fusion Fittings are typically produced in SDR 7 and are pressure rated in accordance with industry and regulatory guidelines for natural gas or water @73°F. Pressure ratings are subject to change depending on ambient temperatures. Pressure ratings vary according to wall thickness and the design factor for the intended application, see below for ratings:

Fitting SDR	Pressure Rating (PSI) @ 73° F (23° C)			
	Water (.63 DSF)	Water (.5 DSF)	Natural Gas (.32 DSF) US	Natural Gas (.4 DSF) Canada
7	335	265	170*	215*
9	250	200	125*	160*
11	200	160	100	125
13.5	160	125	80	100
17	125	100	65	80
21	100	80	50	65
26	80	65	40	50
32.5	65	50	30	40

\* Subject to maximum operating pressure limits of regulatory requirements.

Minimum wall thickness for plastic piping gas distribution systems is limited to .062".

Above listed pressure ratings based on 73°F ambient temperature. Pressure ratings subject to derating depending on temperature.

**PRESSURE TESTING:**

Pressure testing can be conducted in accordance with the recommendations of the pipe manufacturer, or as described in ASTM F2164 STANDARD PRACTICE FOR FIELD LEAK TESTING OF POLYETHYLENE (PE) PRESSURE PIPING SYSTEMS USING HYDROSTATIC PRESSURE, typically 1.5 x's the rated working pressure not exceeding 8 hours in duration for a single test.

**MAXIMUM OPERATING TEMPERATURE:**

The maximum operating temperature of PE4710 Socket Fusion Fittings is 140°F. Pressure de-rating factors should be considered when operating systems above the 73°F stated pressure rating, to maintain the 50 year substantiated long-term hydrostatic strength of the polyethylene material.

**STORAGE/SHELF LIFE:**

Black high density polyethylene resin contains a minimum of 2% of a finely dispersed concentration of carbon black which provides protection from UV effects. Even so, it is recommended that fittings which are stored for extended periods (two years or greater) be stored indoors in their original packaging. Fittings stored indoors in their original packaging have a virtually unlimited shelf-life.

**CHEMICAL RESISTANCE:**

Polyethylene generally exhibits strong resistance to many chemical compounds. Known chemical resistance characteristics at specified temperatures can be found in PPI Technical Report TR-19.

**INSTALLATION:**

These fittings are intended to be installed by the Socket Heat Fusion method. Fusion jointing procedures can be obtained from Central Plastics upon request and may also be available from the pipe or tubing manufacturer. These fittings can be socket fusion joined to pipe or fittings manufactured from any like or similar resin. Fusion jointing should only be attempted by persons who have been trained and have qualified joints through destructive testing.

*Note: This Specification supercedes all previous Product Specifications and is subject to change without notice.*

Approved By:

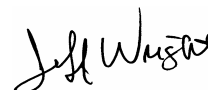

Jeff Wright  
Director of Product Management



## PRODUCT SPECIFICATION

### BUTT FUSION FITTINGS (IPS) PE3408 / PE4710 HDPE BLACK

FAMILY: BUTT FUSION  
PRODUCT: PE FITTING  
TYPE: SPECIFICATION  
DOC: PS-102  
REV: 4  
FILE: PE BF FIT-PE3408  
DATE: 4/17/2009  
PAGES: 2

#### **SCOPE:**

This document describes the standard specifications and features related to Georg Fischer Central Plastics' injection molded PE4710 (formerly PE3408) Butt Fusion Fittings for pressure piping systems.

#### **SIZES:**

1/2" CTS through 2" CTS. TEE, 90 DEGREE ELBOW, REDUCER, CAP,  
1/2" IPS through 12" IPS. TEE, 90 DEGREE ELBOW, 45 DEGREE ELBOW, REDUCER, CAP, PURGE FITTING,

#### **REQUIREMENTS:**

ASTM D2513 Specification for Thermoplastic Gas Pressure Pipe, Tubing, and Fittings  
ASTM D3350 Specification for Polyethylene Plastic Pipes and Fittings Materials  
ASTM D3261 Specification for Butt Heat Fusion Polyethylene (PE) Plastic Fittings for Polyethylene (PE) Plastics Pipe and Tubing

#### **REFERENCE DOCUMENTS:**

PPI TR-19 Thermoplastics Piping for the Transport of Chemicals  
PPI TR-31 Underground Installation of Polyolefin Pipe  
PPI TR-33 Generic Butt Fusion Procedure for Polyethylene Gas Pipe  
ASTM D2657 Standard Practice for Heat Fusion Joining of Polyolefin Pipe and Fittings

#### **CERTIFICATIONS/LISTINGS:**

FM 1613 Approval Standard: Plastic Pipe and Fittings for Underground Fire Protection Service  
AWWA C906 Standard for Polyethylene Pressure Pipe and Fittings, 4 in. Through 63 in., for Water Distribution  
FM 1613 Approval Standard: Plastic Pipe and Fittings for Underground Fire Protection Service  
ANSI/NSF 14 Plastic Piping System Components and Related Materials

#### **MATERIALS:**

PE Resin: Pre-blended black high density virgin resin. Recognized by the Plastic Pipe Institute as having a PE3408 / PE4710 / PE100 rating and a Hydrostatic Design Basis of 1600 psi @ 73°F. This resin has a cell classification of 445574C\* in accordance with ASTM D3350.

Note\* Previous editions of ASTM D3350 resulted in cell classifications of 345464C and 345564C.

#### **TEST METHODS:**

ASTM D1598 Time-to-Failure of Plastic Pipe Under Constant Internal Pressure.  
Must exceed 170 hours in 80°C bath @ 670psi Hoop Stress, or  
Must exceed 1000 hours in 80°C bath @ 580psi Hoop Stress, or  
Must exceed 1000 hours in 23°C bath @ 1600psi Hoop Stress.  
*(All methods are considered equivalent)*

ASTM D1599 Short-Term Hydraulic Pressure Failure of Plastics Pipe, Tubing, and Fittings.  
Uniform pressurization until failure between 60 and 70 seconds from start of test. Most result in ductile failure at a pressure great enough to create a 2520psi Hoop Stress.

ASTM D2122 Test Method for Determining Dimensions of Thermoplastic Pipe and Fittings  
Determination of diameter, wall thickness, and length dimensions including procedures for dimensioning molded thermoplastic pipe fittings.

#### **FEATURES:**

Made in USA from pre-blended virgin materials. These fittings are available in various configurations and DR and are primarily intended for use in pressure piping applications. These fittings are compatible for heat fusion to any PE material

made from a like or similar resin. Select sizes can be supplied with AWWA or FM marking. Designed for use on pipe conforming to ASTM F714, D2513, and D3035.

**PRESSURE RATING:**

PE4710 Butt Fusion Fittings are pressure rated in accordance with industry and regulatory guidelines for natural gas or water @73°F. Pressure ratings are subject to change depending on ambient temperatures. Pressure ratings vary according to wall thickness and the design factor for the intended application, see below for ratings:

Fitting SDR	Pressure Rating (PSI) @ 73° F (23° C)			
	Water (.63 DSF)	Water (.5 DSF)	Natural Gas (.32 DSF) US	Natural Gas (.4 DSF) Canada
7	335	265	170*	215*
9	250	200	125*	160*
11	200	160	100	125
13.5	160	125	80	100
17	125	100	65	80
21	100	80	50	65
26	80	65	40	50
32.5	65	50	30	40

\* Subject to maximum operating pressure limits of regulatory requirements.

Minimum wall thickness for plastic piping gas distribution systems is limited to .062".

Above listed pressure ratings based on 73°F ambient temperature. Pressure ratings subject to derating depending on temperature.

**PRESSURE TESTING:**

Pressure testing can be conducted in accordance with the recommendations of the pipe manufacturer, or as described in ASTM F2164 *STANDARD PRACTICE FOR FIELD LEAK TESTING OF POLYETHYLENE (PE) PRESSURE PIPING SYSTEMS USING HYDROSTATIC PRESSURE*, typically 1.5 x's the rated working pressure not exceeding 8 hours in duration for a single test.

**MAXIMUM OPERATING TEMPERATURE:**

The maximum operating temperature of PE4710 Butt Fusion Fittings is 140°F. Pressure de-rating factors should be considered when operating systems above the 73°F stated pressure rating, to maintain the 50 year substantiated long-term hydrostatic strength of the polyethylene material.

**STORAGE/SHELF LIFE:**

Black high density polyethylene resin contains a minimum of 2% of a finely dispersed concentration of carbon black which provides protection from UV effects. Even so, it is recommended that fittings which are stored for extended periods (two years or greater) be stored indoors in their original packaging. Fittings stored indoors in their original packaging have a virtually unlimited shelf-life.

**CHEMICAL RESISTANCE:**

Polyethylene generally exhibits strong resistance to many chemical compounds. Known chemical resistance characteristics at specified temperatures can be found in PPI Technical Report TR-19.

**INSTALLATION:**

These fittings are compatible for heat fusion by butt, socket, or electrofusion joining products. They can be heat fusion joined to pipe or fittings manufactured from like or similar resin. Qualified mechanical joining products can be used to join these fittings, consult the manufacturer for recommendations. Fusion jointing should only be attempted by persons who have been trained and have qualified joints through destructive testing.

*Note: This Specification supercedes all previous Product Specifications and is subject to change without notice.*

Approved By:



Jeff Wright  
Director of Product Management



## PRODUCT SPECIFICATION

### BUTT FUSION FLANGE ADAPTER PE3408/PE4710/PE100 HDPE BLACK

FAMILY:	BUTT FUSION
PRODUCT:	PE FA
TYPE:	SPECIFICATION
DOC:	PS-104
REV:	2
FILE:	PE BF FA-PE3408-PE4710
DATE:	8/23/2006
PAGES:	2

#### **SCOPE:**

This document describes the standard specifications and features related to Central Plastics' IPS and DIPS sized PE4710 Butt Fusion Flange Adapter for pressure piping systems.

#### **SIZES:**

2" IPS through 24" IPS  
4" DIPS through 24" DIPS.

#### **REQUIREMENTS:**

ASTM D2513	<u>Specification for Thermoplastic Gas Pressure Pipe, Tubing, and Fittings</u>
ASTM D3350	<u>Specification for Polyethylene Plastic Pipes and Fittings Materials</u>
ASTM D3261	<u>Specification for Butt Heat Fusion Polyethylene (PE) Plastic Fittings for Polyethylene (PE) Plastics Pipe and Tubing</u>

#### **REFERENCE DOCUMENTS:**

PPI TR-19	<u>Thermoplastics Piping for the Transport of Chemicals</u>
PPI TR-31	<u>Underground Installation of Polyolefin Pipe</u>
PPI TR-33	<u>Generic Butt Fusion Procedure for Polyethylene Gas Pipe</u>
ASTM D2657	<u>Standard Practice for Heat Fusion Joining of Polyolefin Pipe and Fittings</u>
ASTM F714	<u>Standard Specification for Polyethylene (PE) Plastic Pipe Based on Outside Diameter</u>

#### **CERTIFICATIONS/LISTINGS:**

FM 1613	<u>Approval Standard: Plastic Pipe and Fittings for Underground Fire Protection Service</u>
AWWA C906	<u>Standard for Polyethylene Pressure Pipe and Fittings, 4 in. Through 63 in., for Water Distribution</u>

#### **MATERIALS:**

PE Resin: Pre-blended black high density virgin resin. Recognized by the Plastic Pipe Institute as having a PE3408 / PE4710 / PE100 rating and a Hydrostatic Design Basis of 1600 psi @ 73°F. This resin has a cell classification of 445574C\* in accordance with ASTM D3350.

Note\* Previous editions of ASTM D3350 resulted in cell classifications of 345464C and 345564C.

#### **TEST METHODS:**

ASTM D1598	<u>Time-to-Failure of Plastic Pipe Under Constant Internal Pressure.</u> Must exceed 170 hours in 80°C bath @ 670psi Hoop Stress, or Must exceed 1000 hours in 80°C bath @ 580psi Hoop Stress, or Must exceed 1000 hours in 23°C bath @ 1600psi Hoop Stress. <i>(All methods are considered equivalent)</i>
ASTM D1599	<u>Short-Term Hydraulic Pressure Failure of Plastics Pipe, Tubing, and Fittings.</u> Uniform pressurization until failure between 60 and 70 seconds from start of test. Must result in ductile failure at a pressure great enough to create a 2520psi Hoop Stress.
ASTM D2122	<u>Test Method for Determining Dimensions of Thermoplastic Pipe and Fittings</u> Determination of diameter, wall thickness, and length dimensions including procedures for dimensioning molded thermoplastic pipe fittings.

**FEATURES:**

Made in USA from pre-blended virgin materials. These fittings are available in various configurations and DR and are primarily intended for use in pressure piping applications. These fittings are compatible for heat fusion to any PE material made from a like or similar resin. Supplied with AWWA C906 marking. Can be supplied with FM certification marking. Can be supplied beveled for butterfly valves.

**PRESSURE RATING:**

Central Plastics PE3408 Butt Fusion Flange Adapters are pressure rated in accordance with industry and regulatory guidelines for gas (where applicable) and water @73°F. Pressure ratings are subject to de-rating depending on ambient temperatures. Pressure ratings vary according to wall thickness, see below for ratings:

Fitting SDR	Pressure Rating (PSI) @ 73° F (23° C)			
	Water (.63 DSF)	Water (.5 DSF)	Natural Gas (.32 DSF) US	Natural Gas (.4 DSF) Canada
7	335	265	170*	215*
9	250	200	125*	160*
11	200	160	100	125
13.5	160	125	80	100
17	125	100	65	80
21	100	80	50	65
26	80	65	40	50
32.5	65	50	30	40

\* Subject to maximum operating pressure limits of regulatory requirements.

Above listed pressure ratings based on 73°F ambient temperature. Pressure ratings subject to derating depending on temperature.

**PRESSURE TESTING:**

Pressure testing can be conducted in accordance with the recommendations of the pipe manufacturer, or as described in ASTM F2164 STANDARD PRACTICE FOR FIELD LEAK TESTING OF POLYETHYLENE (PE) PRESSURE PIPING SYSTEMS USING HYDROSTATIC PRESSURE, typically 1.5 x's the rated working pressure not exceeding 8 hours in duration for a single test.

**MAXIMUM OPERATING TEMPERATURE:**

The maximum operating temperature of PE3408 Butt Fusion Fittings is 140°F. Pressure de-rating factors should be considered when operating systems above the 73°F stated pressure rating, to maintain the 50 year substantiated long-term hydrostatic strength of the polyethylene material.

**STORAGE/SHELF LIFE:**

Black high density polyethylene resin contains a minimum of 2% of a finely dispersed concentration of carbon black which provides some degree of protection from UV effects. Even so, it is recommended that fittings which are stored for extended periods (two years or greater) be stored indoors in their original packaging. Fittings stored indoors in their original packaging have a virtually unlimited shelf-life.

**CHEMICAL RESISTANCE:**

Polyethylene exhibits strong resistance to many chemical compounds. Known chemical resistance characteristics at specified temperatures can be found in PPI Technical Report TR-19.

**INSTALLATION:**

These fittings are compatible for heat fusion by butt, socket, or electrofusion joining products. They can be heat fusion joined to pipe or fittings manufactured from like or similar resin. Qualified mechanical joining products can be used to join these fittings, consult the manufacturer for recommendations. Fusion jointing should only be attempted by persons who have been trained and have qualified joints through destructive testing. Care should be used when installing to butterfly valves to ensure that there is no interference, verification is the responsibility of the user.

*Note: This Specification supercedes all previous Product Specifications and is subject to change without notice.*

Approved By:



Jeff Wright  
Director of Product Management



## PRODUCT SPECIFICATION

### BUTT FUSION MECHANICAL JOINT (MJ) ADAPTER PE3408/PE4710/PE100 HDPE BLACK

FAMILY: BUTT FUSION  
PRODUCT: PE MJ Adapter  
TYPE: SPECIFICATION  
DOC: PS-105  
REV: 2  
FILE: PE BF MJ-PE3408  
DATE: 8/30/2006  
PAGES: 2

#### **SCOPE:**

This document describes the standard specifications and features related to Central Plastics' IPS and DIPS sized PE3408 Butt Fusion Mechanical Joint (MJ) Adapter for pressure piping systems.

#### **SIZES:**

3" IPS through 24" IPS  
3" DIPS through 24" DIPS.

#### **REQUIREMENTS:**

ASTM D3350 Specification for Polyethylene Plastic Pipes and Fittings Materials  
ASTM D3261 Specification for Butt Heat Fusion Polyethylene (PE) Plastic Fittings for Polyethylene (PE) Plastics Pipe and Tubing

#### **REFERENCE DOCUMENTS:**

PPI TR-19 Thermoplastics Piping for the Transport of Chemicals  
PPI TR-31 Underground Installation of Polyolefin Pipe  
PPI TR-33 Generic Butt Fusion Procedure for Polyethylene Gas Pipe  
ASTM D2657 Standard Practice for Heat Fusion Joining of Polyolefin Pipe and Fittings  
ASTM F714 Standard Specification for Polyethylene (PE) Plastic Pipe Based on Outside Diameter

#### **CERTIFICATIONS/LISTINGS:**

FM 1613 Approval Standard: Plastic Pipe and Fittings for Underground Fire Protection Service  
AWWA C906 Standard for Polyethylene Pressure Pipe and Fittings, 4 in. Through 63 in., for Water Distribution

#### **MATERIALS:**

PE Resin: Pre-blended black high density virgin resin. Recognized by the Plastic Pipe Institute as having a PE3408 / PE4710 / PE100 rating and a Hydrostatic Design Basis of 1600 psi @ 73 °F. This resin has a cell classification of 445574C\* in accordance with ASTM D3350. NSF Listed.

Note\* Previous editions of ASTM D3350 resulted in cell classifications of 345464C and 345564C.

#### **TEST METHODS:**

ASTM D1598 Time-to-Failure of Plastic Pipe Under Constant Internal Pressure.  
Must exceed 170 hours in 80°C bath @ 670psi Hoop Stress, or  
Must exceed 1000 hours in 80°C bath @ 580psi Hoop Stress, or  
Must exceed 1000 hours in 23°C bath @ 1600psi Hoop Stress.  
*(All methods are considered equivalent)*

ASTM D1599 Short-Term Hydraulic Pressure Failure of Plastics Pipe, Tubing, and Fittings.  
Uniform pressurization until failure between 60 and 70 seconds from start of test. Must result in ductile failure at a pressure great enough to create a 2520psi Hoop Stress.

ASTM D2122 Test Method for Determining Dimensions of Thermoplastic Pipe and Fittings  
Determination of diameter, wall thickness, and length dimensions including procedures for dimensioning molded thermoplastic pipe fittings.

#### **FEATURES:**

Made in USA from pre-blended virgin materials. These fittings are available in various configurations and DR and are primarily intended for use in pressure piping applications. These fittings are compatible for heat fusion to any PE material made from a like or similar resin. Supplied with AWWA C906 marking. Can be supplied with FM certification marking. Can be supplied beveled for butterfly valves. Can be supplied with accessory kit including gasket, ring, and special length bolts.

**PRESSURE RATING:**

Central Plastics PE3408/PE4710 Butt Fusion Mechanical Joint Adapters are pressure rated in accordance with industry and regulatory guidelines for water @73°F. Pressure ratings are subject to de-rating depending on ambient temperatures. Pressure ratings vary according to wall thickness, see below for ratings:

Fitting DR	Pressure Rating (PSI) @ 73° F (23° C)	
	Water (.63 DSF)	Water (.5 DSF)
7	335	265
9	250	200
11	200	160
13.5	160	130
17	125	100
21	100	80
26	80	65
32.5	65	50

Above listed pressure ratings based on 73°F ambient temperature. Pressure ratings subject to derating depending on temperature.

**PRESSURE TESTING:**

Pressure testing can be conducted in accordance with the recommendations of the pipe manufacturer, or as described in ASTM F2164 *STANDARD PRACTICE FOR FIELD LEAK TESTING OF POLYETHYLENE (PE) PRESSURE PIPING SYSTEMS USING HYDROSTATIC PRESSURE*, typically 1.5 x's the rated working pressure not exceeding 8 hours in duration for a single test.

**MAXIMUM OPERATING TEMPERATURE:**

The maximum operating temperature of PE3408 Butt Fusion Fittings is 140°F. Pressure de-rating factors should be considered when operating systems above the 73°F stated pressure rating, to maintain the 50 year substantiated long-term hydrostatic strength of the polyethylene material.

**STORAGE/SHELF LIFE:**

Black high density polyethylene resin contains a minimum of 2% of a finely dispersed concentration of carbon black which provides some degree of protection from UV effects. Even so, it is recommended that fittings which are stored for extended periods (two years or greater) be stored indoors in their original packaging. Fittings stored indoors in their original packaging have a virtually unlimited shelf-life.

**CHEMICAL RESISTANCE:**

Polyethylene exhibits strong resistance to many chemical compounds. Known chemical resistance characteristics at specified temperatures can be found in PPI Technical Report TR-19.

**INSTALLATION:**

These fittings are compatible for heat fusion by butt, socket, or electrofusion joining products. They can be heat fusion joined to pipe or fittings manufactured from like or similar resin. Qualified mechanical joining products can be used to join these fittings, consult the manufacturer for recommendations. Fusion jointing should only be attempted by persons who have been trained and have qualified joints through destructive testing. Care should be used when installing to butterfly valves to ensure that there is no interference, verification is the responsibility of the user.

***Note: This Specification supercedes all previous Product Specifications and is subject to change without notice.***

Approved By:



Jeff Wright  
Director of Product Management



## PRODUCT SPECIFICATION

### SADDLE FUSION FITTINGS HDPE PE3408/PE4710 BLACK

FAMILY:	PE SADDLE
PRODUCT:	SADDLE
TYPE:	SPECIFICATION
DOC:	PS-201
REV:	0
FILE:	SF FIT-PE3408/PE4710
DATE:	4/17/2009
PAGES:	2

#### **SCOPE:**

This document describes the standard specifications and features related to Georg Fischer Central Plastics' PE3408/PE4710 Saddle Fusion Fittings for pressure piping systems. This specification covers Tapping Tees and Branch Saddles labeled as ASTM D2513, D3261, and D2683.

#### **SIZES:**

Butt Fusion Outlet: 1 1/4" through 12" (Main Size) X 1/2" CTS through 4" (Outlet Size)  
Socket Fusion Outlet: 1 1/4" through 8" (Main Size) x 1/2" through 2" (Outlet Size)

#### **REQUIREMENTS:**

ASTM D2513	<a href="#">Specification for Thermoplastic Gas Pressure Pipe, Tubing, and Fittings</a>
ASTM D3350	<a href="#">Specification for Polyethylene Plastic Pipes and Fittings Materials</a>
ASTM D3261	<a href="#">Specification for Butt Heat Fusion Polyethylene (PE) Plastic Fittings for Polyethylene Plastic Pipe</a>
ASTM D2683	<a href="#">Specification for Socket-Type Polyethylene Fittings for Outside Diameter-Controlled Polyethylene Pipe</a>
ASTM D2837	<a href="#">Test Method for Obtaining Hydrostatic Design Basis for Thermoplastic Pipe Materials</a>
ASTM F714	<a href="#">Specification for Polyethylene (PE) Plastic Pipe (SDR-PR) Based on Outside Diameter</a>

#### **REFERENCE DOCUMENTS:**

ASTM D2657	<a href="#">Practice for Heat Fusion Joining of Polyethylene Pipe and Fittings</a>
PPI TR-19	<a href="#">Thermoplastics Piping for the Transport of Chemicals</a>
PPI TR-31	<a href="#">Underground Installation of Polyolefin Pipe</a>
ANSI/NSF 61	<a href="#">Standard for Drinking Water System Components and Health Effects</a>
ASTM D3035	<a href="#">Standard for Polyethylene (PE) Plastic Pipe (DR-PR) Based on Controlled Outside Diameter</a>
ASTM F1290	<a href="#">Standard for Electrofusion Joining Polyolefin Pipe and Fittings</a>
AWWA C906	<a href="#">Standard for Polyethylene Pressure Pipe and Fittings, 4 in. Through 63 in., for Water Distribution</a>
ANSI/NSF 61	<a href="#">Standard for Drinking Water System Components and Health Effects</a>
ASTM F2164	<a href="#">Standard Practice for Field Leak Testing of Polyethylene (PE) Pressure Piping Systems Using Hydrostatic Pressure</a>
IGSHPA	<a href="#">Closed-Loop/Geothermal Heat Pump Systems</a>

#### **CERTIFICATIONS/LISTINGS:**

ANSI/NSF 14	<a href="#">Plastic Piping System Components and Related Materials</a>
AWWA C906	<a href="#">Standard for Polyethylene Pressure Pipe and Fittings, 4 in. Through 63 in., for Water Distribution</a>
FM 1613	<a href="#">Approval Standard: Plastic Pipe and Fittings for Underground Fire Protection Service</a>

#### **MATERIALS:**

PE Resin: Pre-blended black high density virgin resin. Recognized by the Plastic Pipe Institute as having a PE3408 / PE4710 / PE100 rating and a Hydrostatic Design Basis of 1600 psi @ 73°F. This resin has a cell classification of 445574C\* in accordance with ASTM D3350.

Note\* Previous editions of ASTM D3350 resulted in cell classifications of 345464C and 345564C.

#### **TEST METHODS:**

ASTM D1598	<a href="#">Time-to-Failure of Plastic Pipe Under Constant Internal Pressure.</a> Must exceed 170 hours in 80°C bath @ 670psi Hoop Stress, or Must exceed 1000 hours in 80°C bath @ 580psi Hoop Stress, or Must exceed 1000 hours in 23°C bath @ 1600psi Hoop Stress. <i>(All methods are considered equivalent)</i>
ASTM D1599	<a href="#">Short-Term Hydraulic Pressure Failure of Plastics Pipe, Tubing, and Fittings.</a> Uniform pressurization until failure between 60 and 70 seconds from start of test. Most result in ductile failure at a pressure great enough to create a 2520psi Hoop Stress.

**FEATURES:**

Made in USA from pre-blended virgin materials. These fittings are available in various configurations and DR and are intended for use in pressure piping applications for gas, water, process piping, geothermal, sanitary, or other PE systems. These fittings are compatible for heat fusion to any PE material made from a like or similar resin. These fittings can be joined with qualified mechanical fittings deemed suitable by their manufacturer.

**PRESSURE RATING:**

PE4710 Butt Fusion Fittings are pressure rated in accordance with industry and regulatory guidelines for natural gas or water @73°F. Pressure ratings are subject to change depending on ambient temperatures. Pressure ratings vary according to wall thickness and the design factor for the intended application, see below for ratings:

Fitting SDR	Pressure Rating (PSI) @ 73° F (23° C)			
	Water (.63 DSF)	Water (.5 DSF)	Natural Gas (.32 DSF) US	Natural Gas (.4 DSF) Canada
7	335	265	170*	215*
9	250	200	125*	160*
11	200	160	100	125
13.5	160	125	80	100
17	125	100	65	80
21	100	80	50	65
26	80	65	40	50
32.5	65	50	30	40

\* Subject to maximum operating pressure limits of regulatory requirements.

Minimum wall thickness for plastic piping gas distribution systems is limited to .062".

Above listed pressure ratings based on 73°F ambient temperature. Pressure ratings subject to derating depending on temperature.

**PRESSURE TESTING:**

Pressure testing can be conducted in accordance with the recommendations of the pipe manufacturer, or as described in ASTM F2164 STANDARD PRACTICE FOR FIELD LEAK TESTING OF POLYETHYLENE (PE) PRESSURE PIPING SYSTEMS USING HYDROSTATIC PRESSURE, typically 1.5 x's the rated working pressure not exceeding 8 hours in duration for a single test.

**MAXIMUM OPERATING TEMPERATURE:**

The maximum operating temperature of PE4710 Butt Fusion Fittings is 140°F. Pressure de-rating factors should be considered when operating systems above the 73°F stated pressure rating, to maintain the 50 year substantiated long-term hydrostatic strength of the polyethylene material.

**STORAGE/SHELF LIFE:**

Black high density polyethylene resin contains a minimum of 2% of a finely dispersed concentration of carbon black which provides protection from UV effects. Even so, it is recommended that fittings which are stored for extended periods (two years or greater) be stored indoors in their original packaging. Fittings stored indoors in their original packaging have a virtually unlimited shelf-life.

**CHEMICAL RESISTANCE:**

Polyethylene generally exhibits strong resistance to many chemical compounds. Known chemical resistance characteristics at specified temperatures can be found in PPI Technical Report TR-19.

**INSTALLATION:**

These fittings are compatible for heat fusion by butt, socket, or electrofusion joining products. They can be heat fusion joined to pipe or fittings manufactured from like or similar resin. Qualified mechanical joining products can be used to join these fittings, consult the manufacturer for recommendations. Fusion jointing should only be attempted by persons who have been trained and have qualified joints through destructive testing.

*Note: This Specification supercedes all previous Product Specifications and is subject to change without notice.*

Approved By:

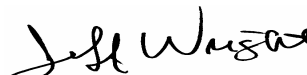

Jeff Wright  
Director of Product Management



# MATERIAL SPECIFICATION

## PE3408/PE4710 POLYETHYLENE RESIN

FAMILY:	POLYETHYLENE
PRODUCT:	PE4710 Resin
TYPE:	SPECIFICATION
DOC:	MS-011
REV:	~
FILE:	PE RESIN MS-011
DATE:	8/22/2007
PAGES:	1

### SCOPE:

This document describes the material requirements for Polyethylene (PE) Resin for use in the manufacture of all PE3408/PE4710 fittings and products in Central Plastics' production facilities. This material may also be used in other product applications if specified.

### Description:

Polyethylene resin designated as PE3408/PE4710 or PE100 and having a PPI long-term hydrostatic design stress and hydrostatic design basis rating. The resin shall be pre-compounded virgin material. Resin shipments shall be accompanied by a certificate of analysis from the producer upon receipt.

### Controlling Specification:

ASTM D3350 [Specification for Polyethylene Plastics Pipe and Fittings Material](#)  
 ASTM D2837 [Method for Obtaining Hydrostatic Design Basis for Thermoplastic Pipe Materials](#)

### Certifications:

All PE resins supplied to Central Plastics shall be accompanied by the supplier's Certificate of Compliance indicating that the material meets all of the requirements previously agreed upon.

### TYPICAL PROPERTIES

PROPERTY	ASTM TEST METHOD	NOMINAL VALUE
Cell Classification	ASTM D3350	345464C (minimum)
Density, gm/cc (Natural)	ASTM D4883	0.948 g/cc
Density, gm/cc (Black)	ASTM D4883	0.959 g/cc
Melt Index, gm/10 min. (190C / 21.60 kg)	ASTM D1238	8.0 g/10 min
Tensile Strength	ASTM D638	
@ Yield (2 in. / min.)		3625 psi
@ Break (2 in. / min.)		5500 psi
Elongation @ Break (2 in. / min.)	ASTM D638	> 600%
Flexural Modulus (2% Secant - 1)	ASTM D790	>150,000 psi
Notched Izod Impact Strength	ASTM D256	9 ft-lbf/in
Hardness (Shore D)	ASTM D2240	66
Vicat Softening Point	ASTM D1525	259°F
Brittleness Temperature	ASTM D746	<-180°F
Hydrostatic Design Basis	ASTM D2837	
@23C		1600 psi
@60C		1000 psi
ESCR (Condition C)	ASTM D1693	>5000 hours
Notched Tensile (PENT)	ASTM F1473	>8000 hours
Carbon Black Concentration	ASTM D1603	>2%

*Note: This Specification supercedes all previous Material Specifications and is subject to change without notice.*

Approved By:

Jeff Wright  
 Director of Product Management



# Figure # 937

## Ductile Iron Wafer Style Butterfly Valve

### Product Features

- 200 PSI Sizes 2"-12"
- 150 PSI Sizes 14" - UP
- Ductile Iron Body
- Wafer Style Body
- Cartridge Seat
- ISO 5211 Mounting Flange
- MSS-SP-67



### Figure Number Breakdown (Example 937DNSL)

Disc Matl.	Seat Matl.	Stem Matl.	Topworks
B = Aluminum Bronze	E = EPDM	M = 316 SS.	L = Lever
D = Ductile Iron w/ Nickel plating	N = Buna N	S = 416 SS.	G = Gear
M = 316 Stainless Steel	-----	-----	X = Bare Stem

### Materials & Specifications

Item	Description	Material
1	Body	Ductile Iron
2	Disc	Alum. Bronze, Ductile Iron or 316 SS.
3	Seat	Buna or EPDM
4	Stem	416 or 316 Stainless Steel
5	Bushings	PTFE
6	O-Ring	NBR
7	Taper Pin	Stainless Steel
8	Seat Support	Plastic

Note: Ductile Iron Disc are electroless Nickel plated

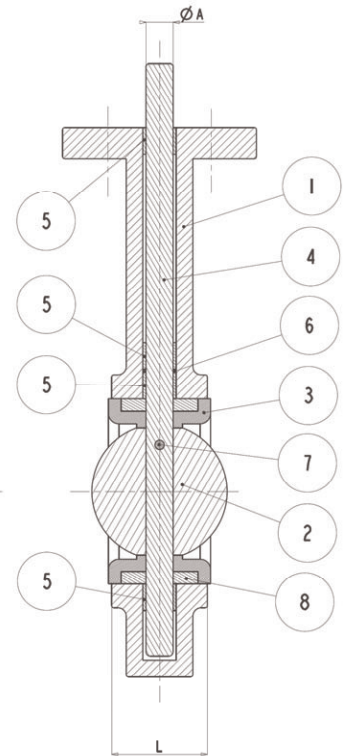

### Dimensions, Weights (inches-lbs.) & Valve Data

Size	2"	2-1/2"	3"	4"	5"	6"	8"	10"	12"	14"	16"	18"	20"	24"
HA	2.99	3.5	3.74	4.49	5.0	5.51	6.81	7.99	9.57	10.51	11.73	12.52	13.74	16.14
HB	6.38	6.89	7.13	7.87	8.39	8.86	10.24	11.5	13.27	14.49	15.75	16.61	18.86	22.13
HC	1.26	1.26	1.26	1.26	1.26	1.26	1.77	1.77	1.77	1.77	2.01	2.01	2.52	2.8
L	1.69	1.81	1.81	2.05	2.2	2.2	2.36	2.68	3.07	3.07	4.02	4.49	5.0	6.0
ØK	4.75	5.5	6.0	7.5	8.5	9.5	11.75	14.25	17.0	18.75	21.25	22.75	25.0	29.5
ØF	.75	.75	.75	.75	.88	.88	.88	1.0	1.0	1.12	1.12	1.25	1.25	1.38
ØA	.5	.5	.5	.63	.75	.75	.87	1.13	1.25	1.25	1.31	1.5	1.62	1.99
N	4	4	4	4	4	4	4	4	4	4	4	4	4	4
Wt. lever	8	9	12	15	20	22	36	46	74	-	-	-	-	-
Wt. Gear	24	25	28	31	36	38	55	65	93	118	177	225	373	538

### Seating torques (inch/lbs.)

PSI	2"	2-1/2"	3"	4"	5"	6"	8"	10"	12"	14"	16"	18"	20"	24"
50	100	150	207	290	423	599	1060	1671	2568	2640	4260	6287	8360	15427
100	106	163	220	323	481	691	1183	1872	2795	3070	4880	7243	9180	16813
150	111	176	232	357	540	783	1307	2074	3023	3500	5500	8200	10000	18200
200	117	189	244	390	598	875	1430	2275	3250	-	-	-	-	-

All torque values shown are for wet (water and other non-lubricating media) on-off service. For dry services (dry gas, etc.) multiply values by 1.15. For lubed service (clean, non-abrasive lubricating media) multiply values by .85. These values do not include a safety factor. An appropriate safety factor should be used when sizing any actuator.

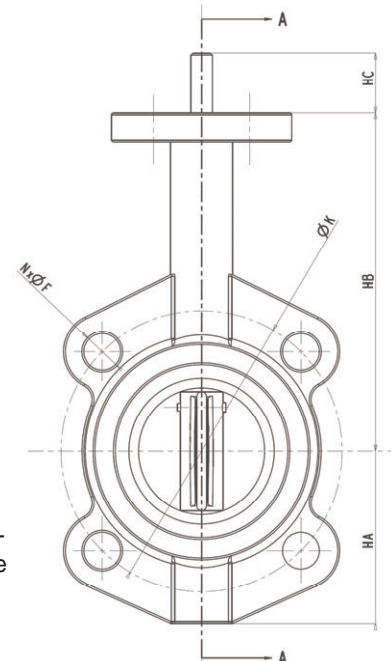



**Figure # 937**

Ductile Iron Wafer Style Butterfly Valve

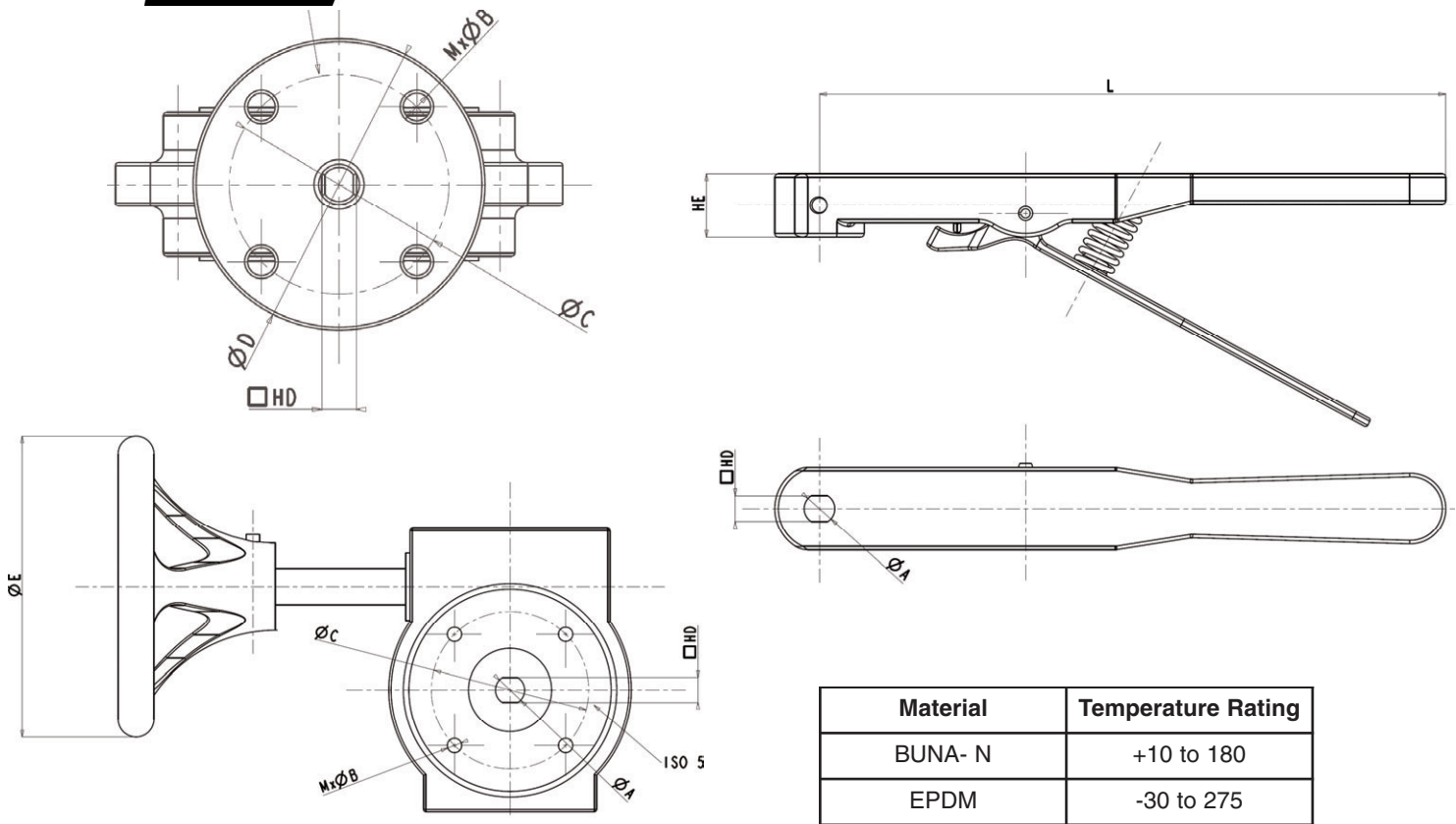

Material	Temperature Rating
BUNA- N	+10 to 180
EPDM	-30 to 275

**Dimensions (inches) of Stem, Lever and Gear Mounting Information**

Size	2"	2-1/2"	3"	4"	5"	6"	8"	10"	12"	14"	16"	18"	20"	24"
ØA	.5	.5	.5	.63	.75	.75	.87	1.13	1.25	1.25	1.31	1.5	1.62	1.99
HD	.39	.39	.39	.47	.55	.55	.67	.87	.94	.94	1.06	1.06	1.26	1.42
HE	1.06	1.06	1.06	1.06	1.06	1.06	1.22	1.22	1.22	-	-	-	-	-
L	10.51	10.51	10.51	10.51	10.51	10.51	14.13	14.13	14.13	-	-	-	-	-
E	5.91	5.91	5.91	5.91	5.91	5.91	11.81	11.81	11.81	11.81	11.81	11.81	15.75	15.75
ØC	2.76	2.76	2.76	2.76	2.76	2.76	4.02	4.02	4.92	4.92	6.5	6.5	6.50	10.0
ØD	3.62	3.62	3.62	3.62	3.62	3.62	4.92	4.92	5.91	5.91	8.27	8.27	8.27	11.81
ISO	F07	F07	F07	F07	F07	F07	F10	F10	F12	F12	F16	F16	F16	F25

**Cv Values - Valve Sizing (US Gallons/minute at 1PSI drop)**

Size	Degrees Open									
	10	20	30	40	50	60	70	80	90	
2"	.06	3	7	15	27	44	70	105	115	
2-1/2"	.1	6	12	25	45	75	119	178	196	
3"	.2	9	18	39	70	116	183	275	302	
4"	.3	17	36	78	139	230	364	546	600	
5"	.5	29	61	133	237	392	620	930	1022	
6"	.8	34	94	153	257	422	706	1154	1320	
8"	2	56	154	251	422	693	1158	1892	2165	
10"	3	87	238	385	654	1073	1794	2931	3353	
12"	4	153	417	681	1145	189	3142	5132	5827	
14"	6	183	500	816	1372	2252	3765	6150	7037	
16"	8	271	740	1208	2031	3333	5573	9104	10416	
18"	11	318	867	1417	2382	3909	6535	10676	12215	
20"	14	415	1133	1851	3112	5107	8538	13948	15959	
24"	22	543	1482	2421	4069	668	11165	18240	20869	





# Figure # 938

## Ductile Iron Lug Style Butterfly Valve

### Product Features

- 200 PSI Sizes 2"-12"
- 150 PSI Sizes 14" - UP
- Ductile Iron Body
- Lug Style Body
- Cartridge Seat
- ISO 5211 Mounting Flange
- MSS-SP-67



### Figure Number Breakdown (Example 938DNSL)

Disc Matl.	Seat Matl.	Stem Matl.	Topworks
B = Aluminum Bronze	E = EPDM	M = 316 SS.	L = Lever
D = Ductile Iron w/ Nickel plating	N = Buna N	S = 416 SS.	G = Gear
M = 316 Stainless Steel	-----	-----	X = Bare Stem

### Materials & Specifications

Item	Description	Material
1	Body	Ductile Iron
2	Disc	Alum. Bronze, Ductile Iron or 316 SS.
3	Seat	Buna or EPDM
4	Stem	416 or 316 Stainless Steel
5	Bushings	PTFE
6	O-Ring	NBR
7	Taper Pin	Stainless Steel
8	Seat Support	Plastic

Note: Ductile Iron Disc are electroless Nickel plated

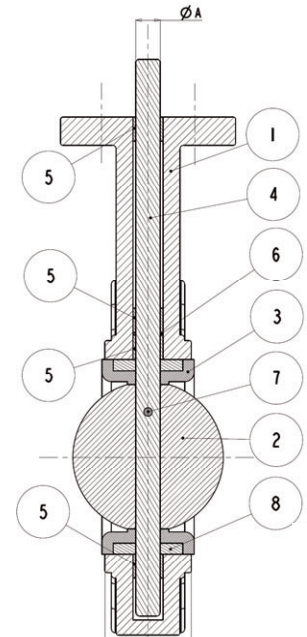

### Dimensions, Weights (inches-lbs.) & Valve Data

Size	2"	2-1/2"	3"	4"	5"	6"	8"	10"	12"	14"	16"	18"	20"	24"
HA	2.99	3.5	3.74	4.49	5.0	5.51	6.81	7.99	9.33	10.98	11.97	14.25	14.49	17.48
HB	6.38	6.89	7.13	7.87	8.39	8.86	10.24	11.5	13.27	14.49	15.75	16.61	18.86	22.13
HC	1.26	1.26	1.26	1.26	1.26	1.26	1.77	1.77	1.77	1.77	2.01	2.01	2.52	2.8
L	1.69	1.81	1.81	2.05	2.2	2.2	2.36	2.68	3.07	3.07	4.02	4.49	5.0	6.0
ØK	4.75	5.5	6.0	7.5	8.5	9.5	11.75	14.25	17.0	18.75	21.25	22.75	25.0	29.5
ØF	5/8-11	5/8-11	5/8-11	5/8-11	3/4-10	3/4-10	3/4-10	7/8-9	7/8-9	1"-8	1"-8	1-1/8-8	1-1/8-8	1-1/4-7
ØA	.5	.5	.5	.63	.75	.75	.87	1.13	1.25	1.25	1.31	1.5	1.62	1.99
N # holes	4	4	4	8	8	8	8	12	12	12	16	16	20	20
Wt. lever	9	10	16	28	30	33	53	76	109	-	-	-	-	-
Wt. Gear	25	26	32	44	46	49	72	95	128	178	255	290	494	708

### Seating torques (inch/lbs.)

PSI	2"	2-1/2"	3"	4"	5"	6"	8"	10"	12"	14"	16"	18"	20"	24"
50	100	150	207	290	423	599	1060	1671	2568	2640	4260	6287	8360	15427
100	106	163	220	323	481	691	1183	1872	2795	3070	4880	7243	9180	16813
150	111	176	232	357	540	783	1307	2074	3023	3500	5500	8200	10000	18200
200	117	189	244	390	598	875	1430	2275	3250	-	-	-	-	-

All torque values shown are for wet (water and other non-lubricating media) on-off service. For dry services (dry gas, etc.) multiply values by 1.15. For lubed service (clean, non-abrasive lubricating media) multiply values by .85. These values do not include a safety factor. An appropriate safety factor should be used when sizing any actuator.

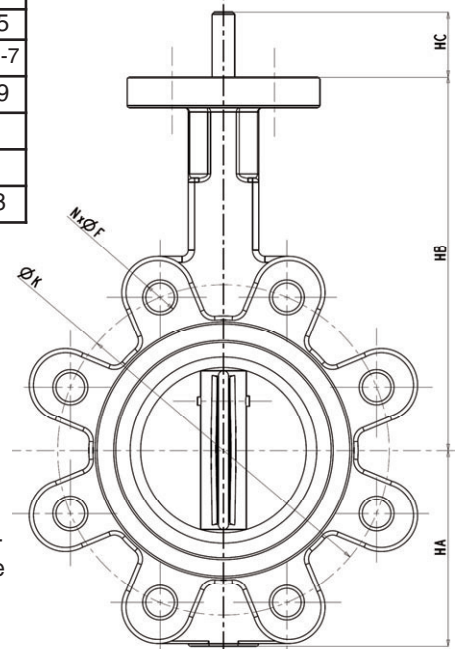

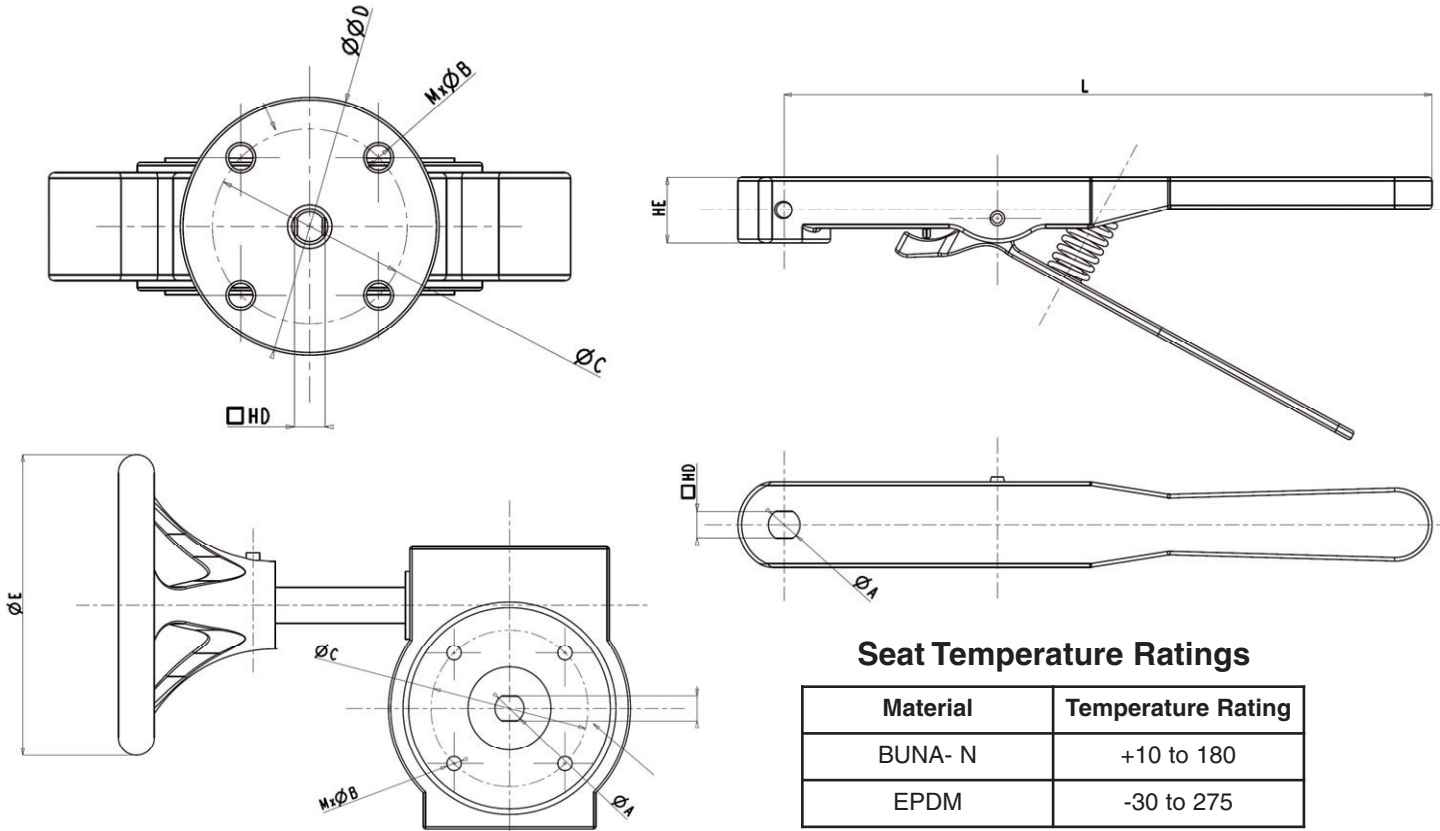

### Seat Temperature Ratings

Material	Temperature Rating
BUNA- N	+10 to 180
EPDM	-30 to 275

### Dimensions (inches) of Stem, Lever and Gear Mounting Information

Size	2"	2-1/2"	3"	4"	5"	6"	8"	10"	12"	14"	16"	18"	20"	24"
$\phi A$	.5	.5	.5	.63	.75	.75	.87	1.13	1.25	1.25	1.31	1.5	1.62	1.99
HD	.39	.39	.39	.47	.55	.55	.67	.87	.94	.94	1.06	1.06	1.26	1.42
HE	1.06	1.06	1.06	1.06	1.06	1.06	1.22	1.22	1.22	-	-	-	-	-
L	10.51	10.51	10.51	10.51	10.51	10.51	14.13	14.13	14.13	-	-	-	-	-
E	5.91	5.91	5.91	5.91	5.91	5.91	11.81	11.81	11.81	11.81	11.81	11.81	15.75	15.75
$\phi C$	2.76	2.76	2.76	2.76	2.76	2.76	4.02	4.02	4.92	4.92	6.5	6.5	6.50	10.0
$\phi D$	3.62	3.62	3.62	3.62	3.62	3.62	4.92	4.92	5.91	5.91	8.27	8.27	8.27	11.81
ISO	F07	F07	F07	F07	F07	F07	F10	F10	F12	F12	F16	F16	F16	F25

### Cv Values - Valve Sizing (US Gallons/minute at 1PSI drop)

Size	Degrees Open									
	10	20	30	40	50	60	70	80	90	
2"	.06	3	7	15	27	44	70	105	115	
2-1/2"	.1	6	12	25	45	75	119	178	196	
3"	.2	9	18	39	70	116	183	275	302	
4"	.3	17	36	78	139	230	364	546	600	
5"	.5	29	61	133	237	392	620	930	1022	
6"	.8	34	94	153	257	422	706	1154	1320	
8"	2	56	154	251	422	693	1158	1892	2165	
10"	3	87	238	385	654	1073	1794	2931	3353	
12"	4	153	417	681	1145	189	3142	5132	5827	
14"	6	183	500	816	1372	2252	3765	6150	7037	
16"	8	271	740	1208	2031	3333	5573	9104	10416	
18"	11	318	867	1417	2382	3909	6535	10676	12215	
20"	14	415	1133	1851	3112	5107	8538	13948	15959	
24"	22	543	1482	2421	4069	668	11165	18240	20869	

# 8901

# 1/4" - 3"

**BRASS BALL VALVE  
TWO-PIECE, FULL-PORT  
600 WOG / 150 SWP  
THREADED ENDS \***

**MSS-SP110  
NSF61-8  
FED. SPEC.  
WW-V-35C, II, BZ, 3, C**

**SA**  
C US  
ANSI Z 21.15-1997 Z CGA 9.1-M97  
3-88 IAS, CR91-002  
ASME 16.33-1990  
CAN/CGA-3.16-M88

**UL** US  
UL 125  
UL 842  
Subject 258

**FM**  
APPROVED  
1140

1/2" through 2" (8901)

## MATERIALS LIST

ITEM	PART	MATERIALS	ASTM SPEC.
1	Body	Brass, Forged	B283
2	Tailpiece	Brass, Forged	B283
3	Ball	Brass w/Chrome Plating	B584
4	Ball Seal	PTFE	Commercial
5	Stem	Brass	B16
6	O-Ring	Buna-N	D2006
7	ThrustWasher	PTFE	Commercial
8	Gland Nut	Brass	B16
9	Packing	PTFE	Commercial
10	Handle	Zinc Die Cast	B633
11	Handle Nut	Brass	B16

\* Also Available 8901-07  
(Locks only in closed position)

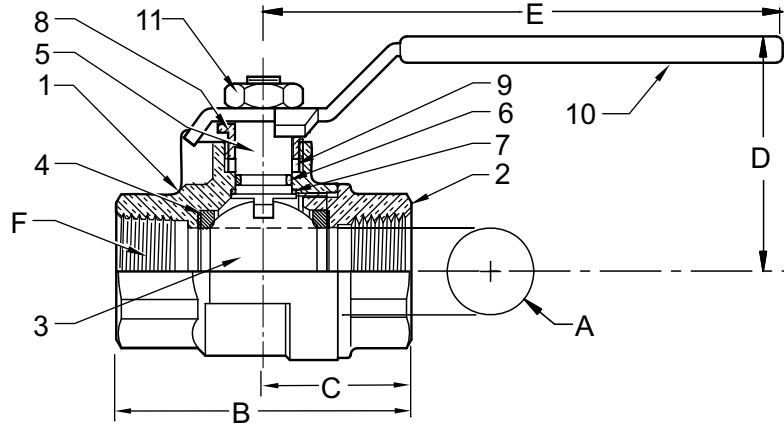

## PRESSURE - TEMPERATURE CHART

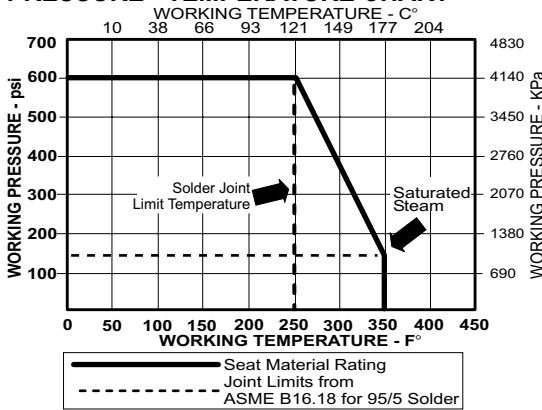

**VACUUM SERVICE TO 29 INCHES Hg**

## DIMENSIONS

VALVE SIZE	UNITS	1/4	3/8	1/2	3/4	1	1-1/4	1-1/2	2	2-1/2	3
A (DIA)	INCHES	.39	.39	.51	.76	1.00	1.26	1.50	2.00	2.48	2.95
	mm	9.9	9.9	13.0	20.1	25.4	32.0	38.1	50.8	63.0	74.9
B	INCHES	1.84	1.84	2.28	2.68	3.11	3.72	4.03	4.72	5.16	6.00
	mm	46.7	46.7	57.9	68.1	79.0	94.5	102.4	119.9	131.1	152.4
C	INCHES	0.92	0.92	1.14	1.34	1.55	1.86	2.02	2.36	2.58	3.00
	mm	23.4	23.4	29.0	34.0	39.4	47.2	51.2	59.9	65.5	76.2
D	INCHES	1.50	1.50	1.61	2.09	2.24	2.76	2.91	3.66	3.94	4.37
	mm	38.1	38.1	40.9	53.1	56.9	70.1	73.9	93.0	100.1	111.0
E	INCHES	3.31	3.31	3.31	4.65	4.65	5.28	5.28	7.87	7.87	7.87
	mm	84.1	84.1	84.1	118.1	118.1	134.1	134.1	199.9	199.9	199.9
F	THREAD SIZE	1/4" NPT	3/8" NPT	1/2" NPT	3/4" NPT	1" NPT	1-1/4" NPT	1-1/2" NPT	2" NPT	2-1/2" NPT	3" NPT
Cv	GPM	11.5	11.5	17.9	40.3	71.6	111.9	161.2	286.6	447.8	644.8
TORQUE	in-lb	19	19	19	58	69	89	124	201	445	563
WEIGHT	lbs	0.37	0.33	0.50	1.03	1.40	2.10	2.86	5.94	7.40	10.47
	Kg	0.17	0.15	0.22	0.47	0.63	0.95	1.30	2.69	3.35	4.75

Rev. 1

The information presented on this sheet is correct at the time of publication. Hammond Valve reserves the right to change design, and/or material specifications without notice. For the most current information access [www.hammondvalve.com](http://www.hammondvalve.com)